

PS

COMBOBOX valves

- Valves with compact design: valve body with integrated sub-base
- High flexibility:
 - > possibility of choosing fitting dimension (4-6-8) according to users' needs
 - > manifolds from 2 up to 20 valve positions
 - > electric and pneumatic control - versions 3/2+3/2 - 5/2 - 5/3
 - > different pressures (vacuum included)
- Electrical connection: external - multipolar - serial connections



TECHNICAL CHARACTERISTICS

Ambient temperature	-5 ÷ +50 °C (PSR: -15 ÷ +50 °C)
Fluid temperature	max +50 °C
Fluid	not dehumidified filtered air 10 µm, lubricated or not
Commutation system	spool
Ways/Positions	3/2+3/2, 5/2, 5/3
Pressure	electric control = max 9 bar pneumatic control = max 10 bar
Control	indirect electro-pneumatic, pneumatic
Return	mechanical spring, pneumomechanical spring
Connections	tube Ø 4, 6, 8
Nominal Ø	6 mm
Nominal flow rate (NI/min) according to the type of fittings:	
straight - tube Ø8 mm	830
90° elbow - tube Ø8 mm	700
straight - tube Ø6 mm	510
90° elbow - tube Ø6 mm	370
straight - tube Ø4 mm	200
90° elbow - tube Ø4 mm	140

CONSTRUCTIVE CHARACTERISTICS

Valve body	zamak
Seals	nitrile rubber
Actuators	self-extinguishing technopolymer
Spool	aluminum

ELECTRIC CHARACTERISTICS

Electropilot/Coil	B series_U04 - DE (U04)
Voltage	24 V DC (12 V DC upon request)
Power consumption	1,35 W
Protection degree	IP65
Manual override	button with tool - 1 position (PSC) 1-2 position screw (PSP)

CODIFICATION KEY

P	S	C	2	6	0	2	4
1	2	3	4	5			

1 Series	2 Ways	3 Control 14
PSC = separate wires PSP = plug-in PSR = pneumatic	2 = 5/2 6 = 3/2+3/2 NC-NC 3 = 5/3 c.c. 7 = 3/2+3/2 NC-NO 4 = 5/3 o.c. 8 = 3/2+3/2 NO-NO 5 = 5/3 p.c.	2 = pneumatic amplified 6 = electrical amplified

4 Return 12	5 Voltage and coil
0 = pneumatic spring 1 = mechanical spring 2 = pneumatic amplified	3 = pneumatic not amplified 6 = electrical amplified 7 = electrical not amplified
	PSC and PSP series, coils assembled with standard supplied led 24 = 24 V (standard) 12 = 12 V (upon request)

o.c. = open centres c.c. = closed centres p.c. = pressurized centres

Flow rate characteristics

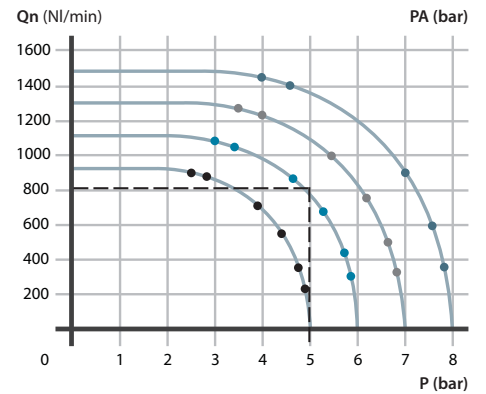

P = Working pressure
PA = Supply pressure
Qn = Flow rate

Single electric impulse



	Symbol	Control	Return	Pressure bar	Times (ms)		Weight Kg	Part no.
					En.	De-en.		
5/2		electrical amplified	pneumomechanical spring	1,8÷9	17	38	0,143	PSC26024
5/2		electrical amplified	mechanical spring	2,2÷9	15	50	0,143	PSC26124

Double electric impulse



	Symbol	Control	Return	Pressure bar	Times (ms)		Weight Kg	Part no.
					En.	De-en.		
5/2		electrical amplified	electrical amplified	0,7÷9	11	11	0,150	PSC26624
5/3 c.c.		electrical amplified	electrical amplified	2,2÷9	15	50	0,155	PSC36624
5/3 o.c.		electrical amplified	electrical amplified	2,2÷9	15	50	0,155	PSC46624
5/3 p.c.		electrical amplified	electrical amplified	2,2÷9	15	50	0,155	PSC56624
3/2 NC + 3/2 NC		electrical amplified	electrical amplified	2÷9	15	33	0,140	PSC66624
3/2 NC + 3/2 NO		electrical amplified	electrical amplified	2÷9	15	33	0,140	PSC76624
3/2 NO + 3/2 NO		electrical amplified	electrical amplified	2÷9	15	33	0,140	PSC86624

o.c. = open centres c.c. = closed centres p.c. = pressurized centres

Solenoid valves are supplied without coil and connector

Manual override on PSC series is with button with tool, 1 position

Single electric impulse



	Simbolo	Coontrol	Return	Pressure bar	Times (ms)		Weight Kg	Part
					En.	De-en.		
5/2		electrical amplified	pneumomechanical spring	1,8÷9	17	38	0,148	PSP26024
5/2		electrical amplified	mechanical spring	2,2÷9	15	50	0,148	PSP26124

Double electric impulse



	Simbolo	Control	Return	Pressure bar	Times (ms)		Weight Kg	Part no.
					En.	De-en.		
5/2		electrical amplified	electrical amplified	0,7÷9	11	11	0,160	PSP26624
5/3 c.c.		electrical amplified	electrical amplified	2,2÷9	15	50	0,165	PSP36624
5/3 o.c.		electrical amplified	electrical amplified	2,2÷9	15	50	0,165	PSP46624
5/3 p.c.		electrical amplified	electrical amplified	2,2÷9	15	50	0,165	PSP56624
3/2 NC + 3/2 NC		electrical amplified	electrical amplified	2÷9	15	33	0,140	PSP66624
3/2 NC + 3/2 NO		electrical amplified	electrical amplified	2÷9	15	33	0,140	PSP76624
3/2 NO + 3/2 NO		electrical amplified	electrical amplified	2÷9	15	33	0,140	PSP86624

o.c. = open centres c.c. = closed centres p.c. = pressurized centres

Solenoid valves are supplied without coil and connector

Manual override on PSC series is with button with tool, 1 position

On PSP series a maximum of 20 coils can be used, restriction due to the connection modules

Single pneumatic impulse



	Symbol	Control	Return	Pressure bar	Times (ms)		Weight Kg	Part no.
					En.	De-en.		
5/2		pneumatic amplified	pneumomechanical spring	1,7÷10	14	33	0,136	PSR220
5/2		pneumatic amplified	mechanical spring	2,2÷10	12	45	0,136	PSR221

Double pneumatic impulse



	Symbol	Control	Return	Pressure bar	Times (ms)		Weight Kg	Part no.
					En.	De-en.		
5/2		pneumatic amplified	pneumatic amplified	0,7÷10	5	5	0,136	PSR222
5/2		pneumatic amplified	pneumatic non amplified	1,1÷10	9	8	0,132	PSR223
5/3 c.c.		pneumatic amplified	pneumatic amplified	2,2÷10	12	45	0,140	PSR322
5/3 o.c.		pneumatic amplified	pneumatic amplified	2,2÷10	12	45	0,140	PSR422
5/3 p.c.		pneumatic amplified	pneumatic amplified	2,2÷10	12	45	0,140	PSR522
3/2 NC + 3/2 NC		pneumatic amplified	pneumatic amplified	2÷10	12	29	0,140	PSR622
3/2 NC + 3/2 NO		pneumatic amplified	pneumatic amplified	2÷10	12	29	0,140	PSR722
3/2 NO + 3/2 NO		pneumatic amplified	pneumatic amplified	2÷10	12	29	0,140	PSR822

o.c. = open centres c.c. = closed centres p.c. = pressurized centres

PSC Series with 26mm inlet plate and 14.5 mm end plate with DIN (EN50022) rail

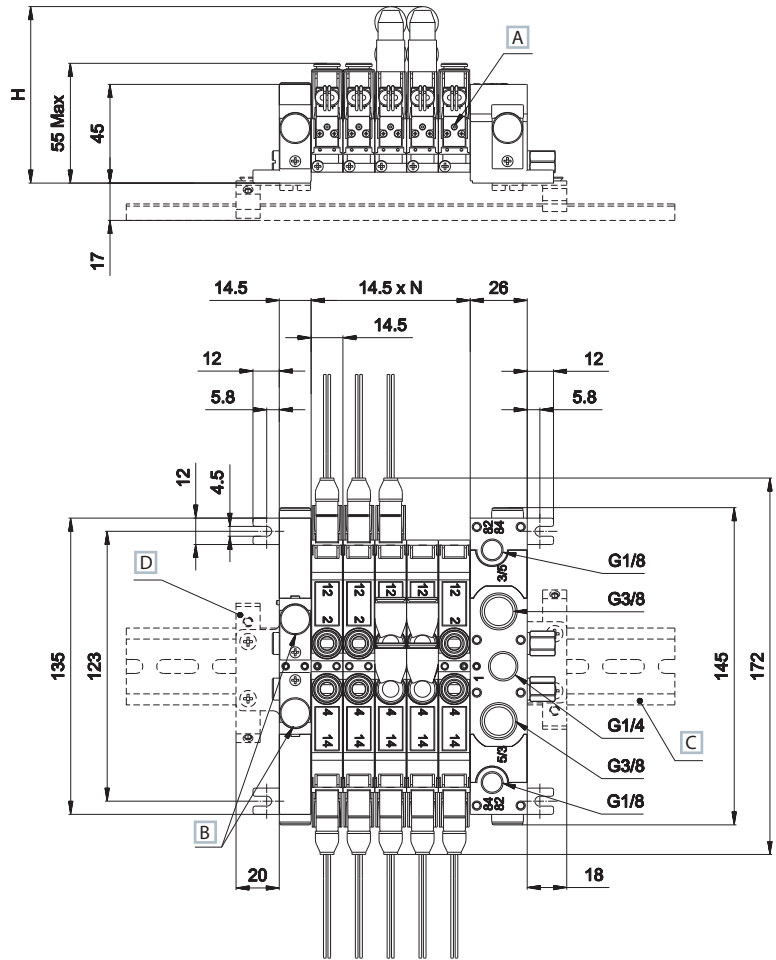

Tube Ø	H
4	72,6
6	76,6
8	80,5

- A Manual override
- B Possibility of supplementary exhausts 3-5
- C Rail DIN (EN 50022)
- D DIN rail connector as optional

- 1 = Supply port
- 2 - 4 = Use
- 3 - 5 = Exhaust
- 14 = Control
- 12 = Return
- 82 = Pilot exhaust side 2
- 84 = Pilot exhaust side 4

N = Number of valve positions

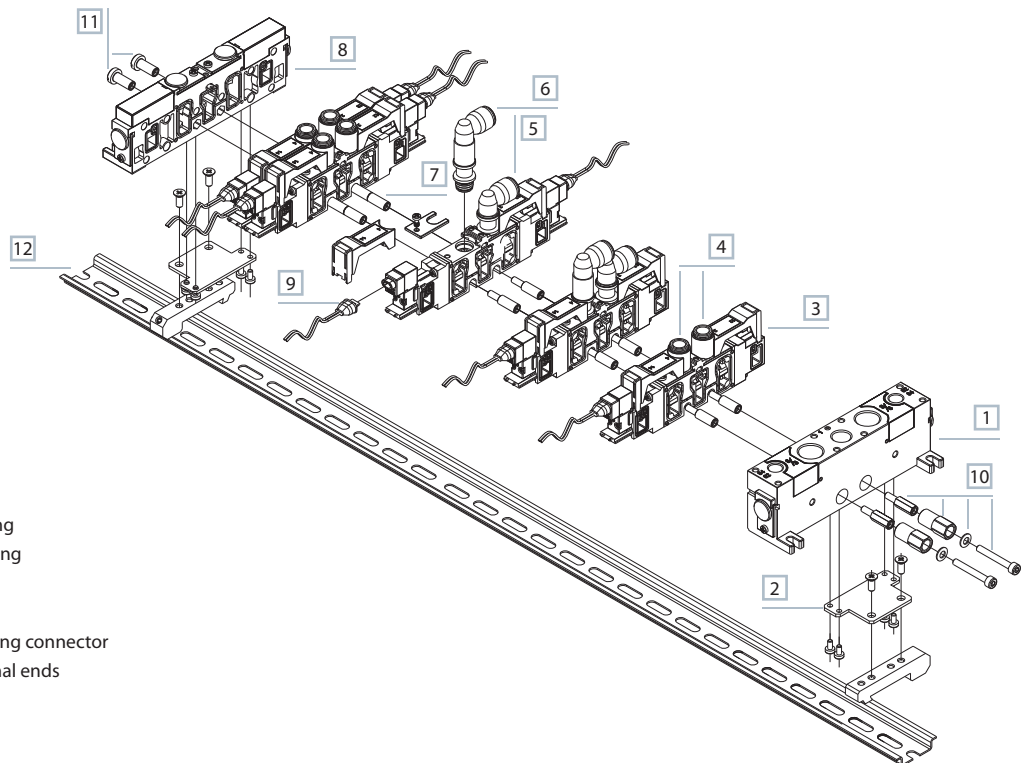

PSC series with 14,5 mm inlet and end plate



Tube Ø	H
4	72,6
6	76,6
8	80,5

- A Manual override
- B Possibility of supplementary exhausts 3 - 5

- 1 = Supply port
- 2 - 4 = Use
- 3 - 5 = Exhaust
- 14 = Control
- 12 = Return
- 82 = Pilot exhaust side 2
- 84 = Pilot exhaust side 4

N = Number of valve positions

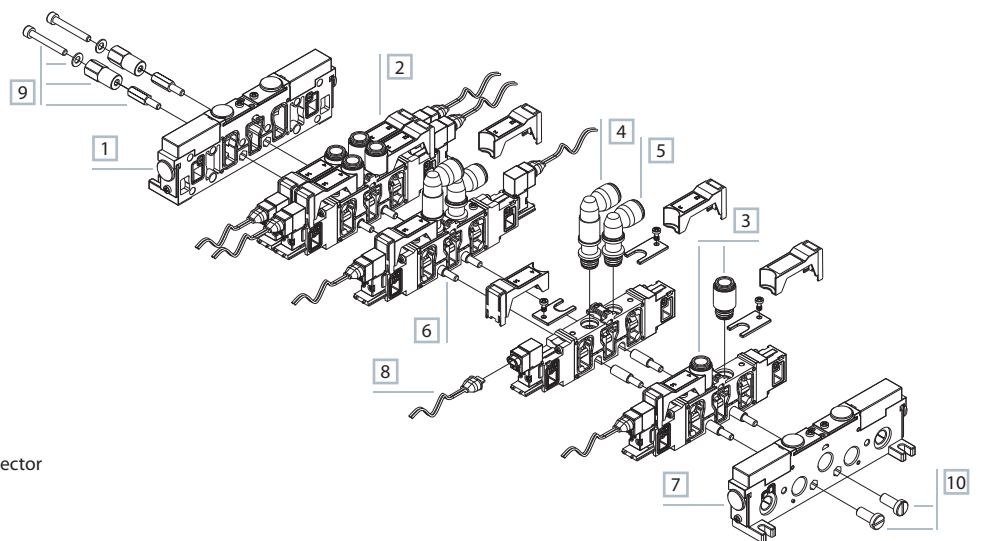
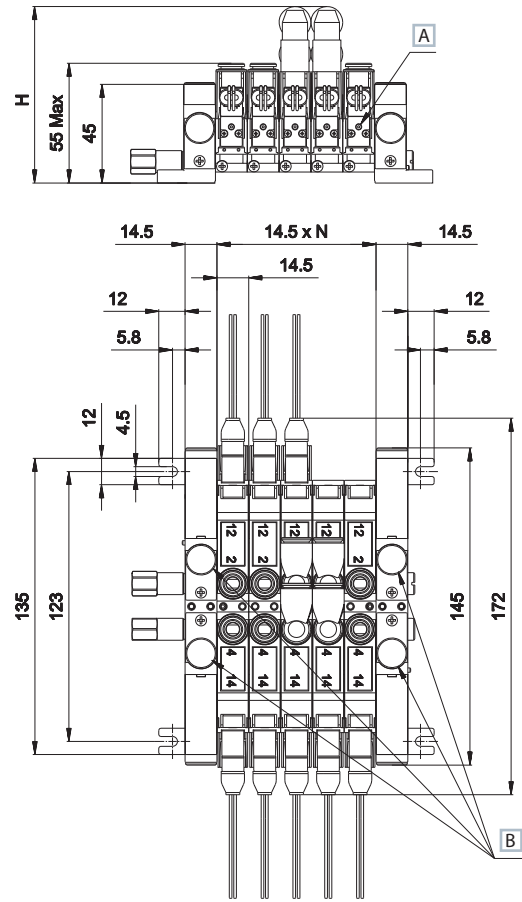

- 1 Inlet plate
- 2 Valve
- 3 Straight fitting
- 4 Swivel low elbow fitting
- 5 Swivel high elbow fitting
- 6 Modular tie-rods
- 7 Blank plate
- 8 Micro double-pole flying connector
- 9 Tie-rods with hexagonal ends
- 10 Counter tie-rods

PSP series with 26mm inlet plate and 14,5 mm end plate with multipolar connector

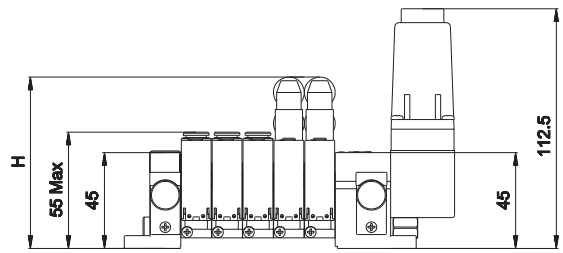

Tube Ø	H
4	72,6
6	76,6
8	80,5

- A Manual override
- B Possibility of supplementary exhausts 3 - 5

- 1 = Supply port
- 2 - 4 = Use
- 3 - 5 = Exhaust
- 14 = Control
- 12 = Return
- 82 = Pilot exhaust side 2
- 84 = Pilot exhaust side 4

N = Number of valve positions

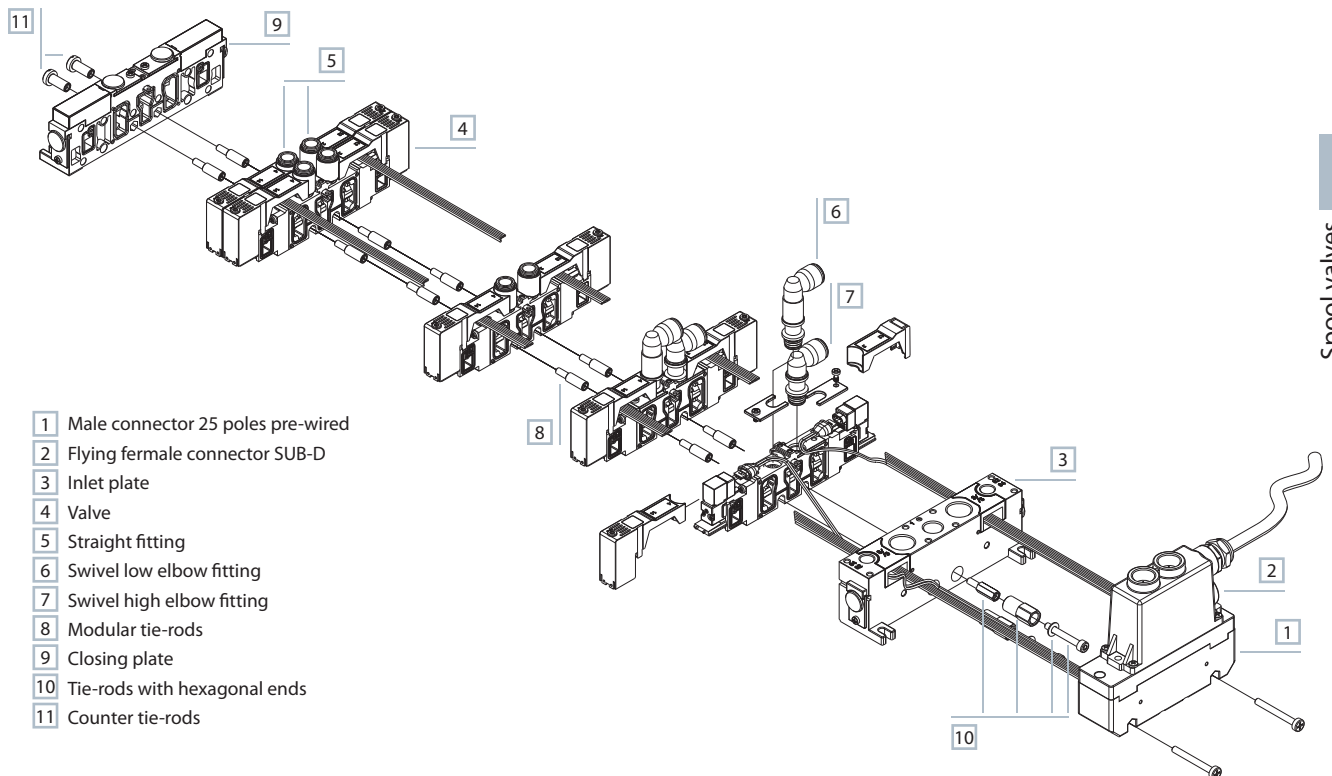
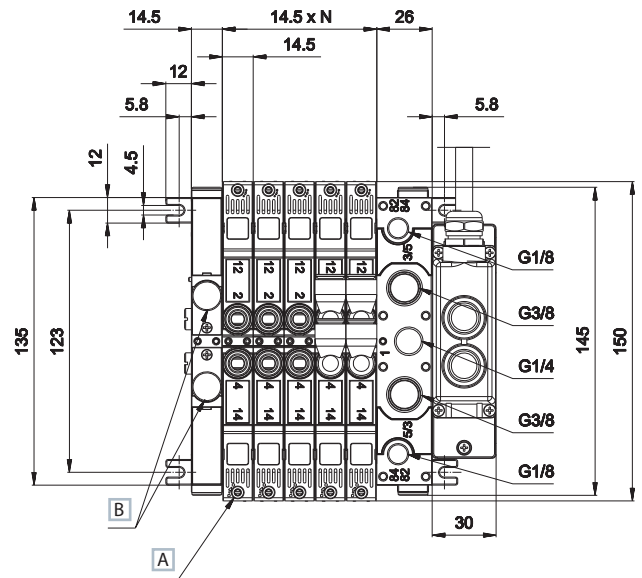

- 1 Male connector 25 poles pre-wired
- 2 Flying female connector SUB-D
- 3 Inlet plate
- 4 Valve
- 5 Straight fitting
- 6 Swivel low elbow fitting
- 7 Swivel high elbow fitting
- 8 Modular tie-rods
- 9 Closing plate
- 10 Tie-rods with hexagonal ends
- 11 Counter tie-rods

PSP series with 26mm inlet plate and 14.5mm end plate with multipolar connector and intermediate plate

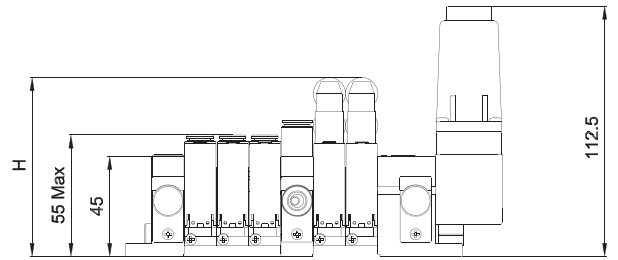

Tube Ø	H
4	72,6
6	76,6
8	80,5

- A Manual override
- B Possibility of supplementary exhausts 3 - 5
- C For type of fittings see page 3_59

- 1 = Supply port
- 2 - 4 = Use
- 3 - 5 = Exhaust
- 14 = Control
- 12 = Return
- 82 = Pilot exhaust side 2
- 84 = Pilot exhaust side 4

N = Number of valve positions

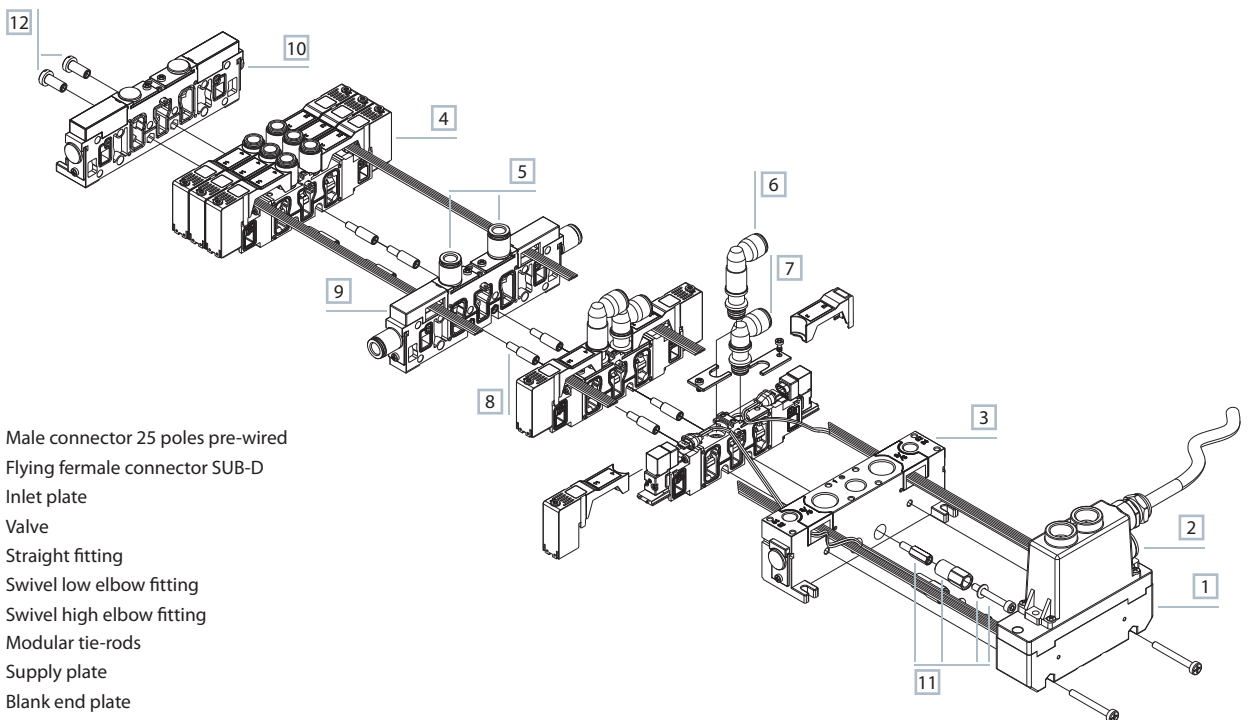
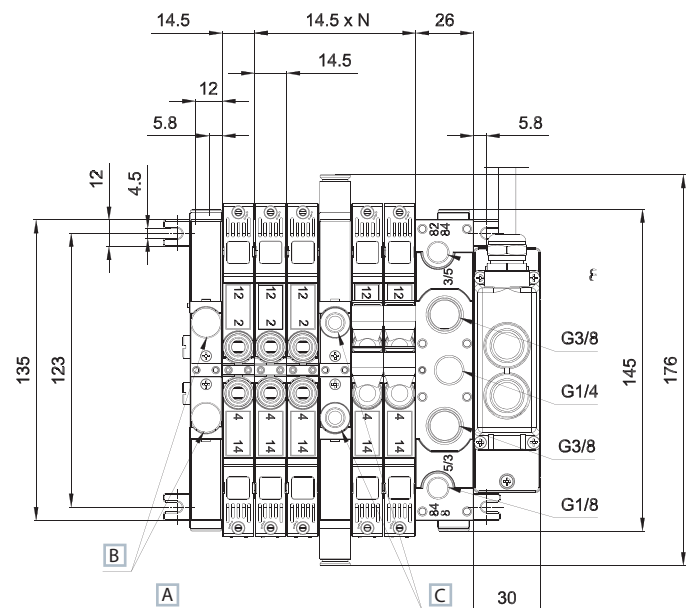

- 1 Male connector 25 poles pre-wired
- 2 Flying female connector SUB-D
- 3 Inlet plate
- 4 Valve
- 5 Straight fitting
- 6 Swivel low elbow fitting
- 7 Swivel high elbow fitting
- 8 Modular tie-rods
- 9 Supply plate
- 10 Blank end plate
- 11 Tie-rods with hexagonal ends
- 12 Counter tie-rods

PSR series with 26mm inlet and end plate 14,5 mm

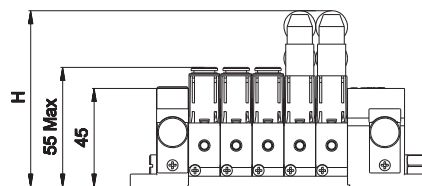

Tube Ø	H
4	72,6
6	76,6
8	80,5

A Possibility of supplementary exhausts 3 - 5

- 1 = Supply port
- 2 - 4 = Use
- 3 - 5 = Exhaust
- 14 = Control
- 12 = Return
- 82 = Pilot exhaust side 2
- 84 = Pilot exhaust side 4

N = Number of valve positions

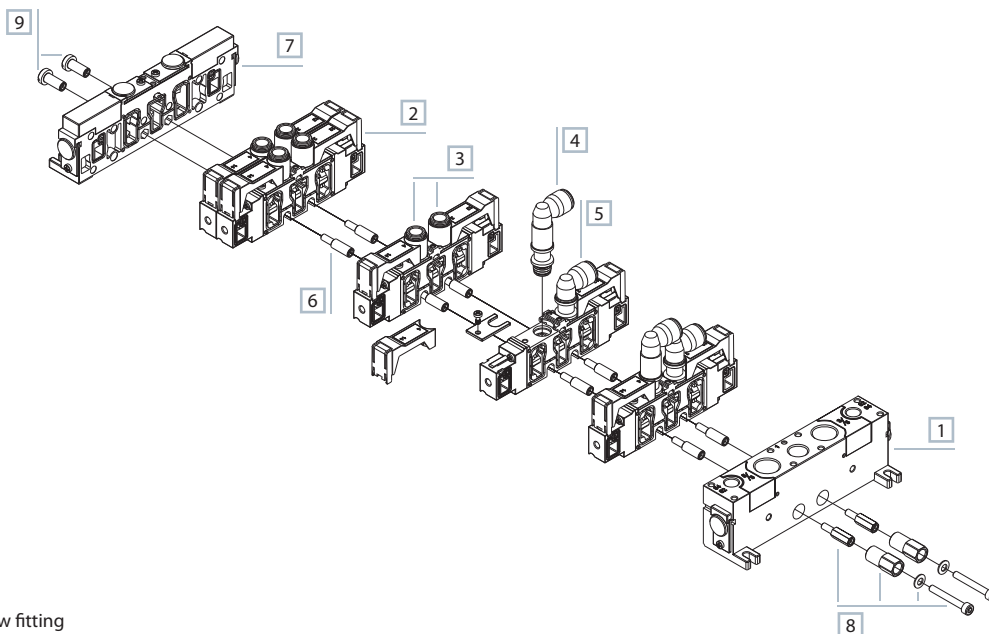
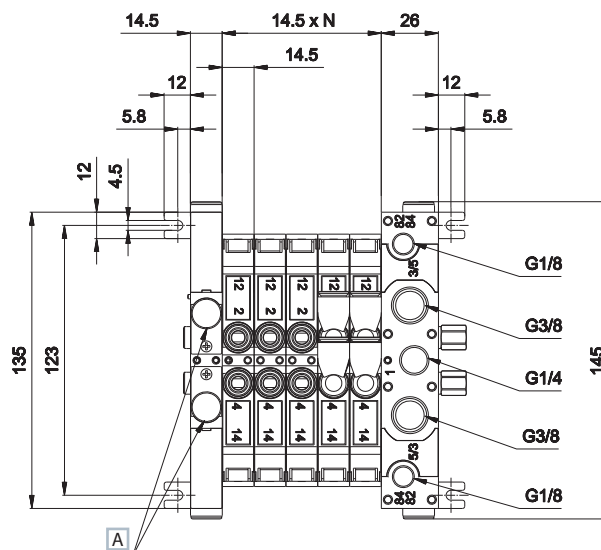

- 1 Inlet plate
- 2 Valve
- 3 Straight fitting
- 4 Swivel low elbow fitting
- 5 Swivel high elbow fitting
- 6 Modular tie-rods
- 7 Blank plate
- 8 Tie-rods with hexagonal ends
- 9 Counter tie-rods

PS14100	PS14200	PS15000	PS15100	PS15200	PS15300*
inlet plate 26 mm internal pilot supply weight: 0,295 Kg	inlet plate 26 mm external pilot supply weight: 0,290 Kg	blank closing plate weight: 0,168 Kg	inlet plate 14,5 mm internal pilot supply weight: 0,167 Kg	inlet plate 14,5 mm external pilot supply weight: 0,162 Kg	intermediate plate 14,5 mm, closed air supply, open exhausts weight: 0,167 Kg

PS15310*	PS15320*	PS15330*	PS15340	PS15350	PS15360
intermediate plate 14,5 mm, open air supply, closed exhausts weight: 0,170 Kg	intermediate plate 14,5 mm, closed air supply and exhaust weight: 0,171 Kg	intermediate plate 14,5 mm open air supply and exhaust weight: 0,165 Kg	intermediate supply plate with closed exhausts and internal pilot supply weight: 0,164 Kg	intermediate supply plate with closed exhausts and external pilot supply weight: 0,164 Kg	intermediate supply plate with open exhausts and internal pilot supply weight: 0,164 Kg

PS15370

intermediate supply plate with open exhausts and external pilot supply
weight: 0,164 Kg

* = For intermediate plate with closed pilot supply ports add suffix 1 to part number.
The intermediate plate occupies one valve place, please keep this in mind for a correct order of the modular tie-rods.

Air supply of the electropilots by means of the end plates for both internal and external air supply. In case there are two different working pressures at the end plates, it is possible to supply all pilots with one of the two pressures (in general with the higher one) or to supply the pilots of each valve group with the working pressure of the same. This can be realized by choosing the correct separation plate. The same is valid if the pressures are more than two: in this case it is necessary to use intermediate supply plates suitably coupled with the separation plates.

PSK100145	PSK200145	PSK200290	PSK200725	PSK300145	PSK401
tie-rods with hexagonal ends (package 50 pcs.) weight: 0,015 Kg	modular tie-rods L1 = 14,5 mm each place (package 100 pcs.) weight: 0,003 Kg	modular tie-rods L2 = 29 mm for 2 places (package 100 pcs.) weight: 0,006 Kg	modular tie-rods L5 = 72,5 mm for 5 places (package 100 pcs.) weight: 0,015 Kg	counter tie-rods (package 50 pcs.) weight: 0,003 Kg	DIN rail adapter plate with screws (package 2 pcs. suitable for all models) weight: 0,066 Kg

GZR-100	GZR-101	GZR-102	GZR-V10004/6/8	GZR-V20004/6/8	GZR-V20L004/6/8
plug (package 2 pcs. suitable for all models) weight: 0,002 Kg	G1/8 Fitting seat reducing plug - gas thread for silencer assembly weight: 0,011 Kg	G1/4 Fitting seat reducing plug - gas thread for silencer assembly weight: 0,0315 Kg	straight fitting (package 50 pcs.) GZR-V10004 tube: 4 mm GZR-V10006 tube: 6 mm GZR-V10008 tube: 8 mm weight: 0,010 Kg	swivel low elbow fitting (package 50 pcs.) GZR-V20004 tube: 4 mm weight: 0,013 Kg GZR-V20006 tube: 6 mm weight: 0,014 Kg GZR-V20008 tube: 8 mm weight: 0,015 Kg	swivel high elbow fitting (package 50 pcs.) GZR-V20L004 tube: 4 mm weight: 0,017 Kg GZR-V20L006 tube: 6 mm weight: 0,021 Kg GZR-V20L008 tube: 8 mm weight: 0,027 Kg

TIM06M/10M/20M

TIM06B/10B

D-530C-100/200

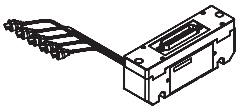

male connector 25 poles pre-wired for monostable valves (M)

TIM06M weight: 0,096 Kg (max 6M)
TIM10M weight: 0,103 Kg (max 10M)
TIM20M weight: 0,127 Kg (max 20M)

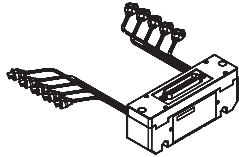

male connector 25 poles pre-wired for bistable valves (B)

TIM06B weight: 0,11 Kg (max 6B)
TIM10B weight: 0,118 Kg (max 10B)

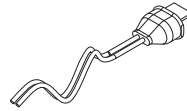

micro double-pole flying connector: stripped and tinned wires with protection guard (package 100 pcs.)

D-530C-100 weight: 0,0047 Kg (wire length 100 cm)
D-530C-200 weight: 0,0093 Kg (wire length 200 cm)

Overall dimensions of fittings on intermediate plates for exhausts 3-5

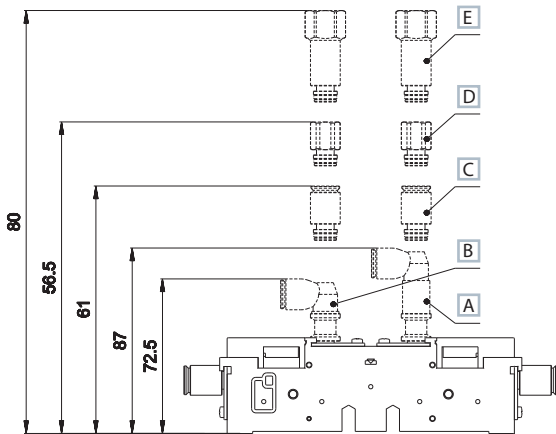

- A** Swivel high elbow fitting for tube Ø8
- B** Swivel low elbow fitting for tube Ø8
- C** Straight fitting for tube Ø8
- D** Fitting for silencer G1/8
- E** Fitting for silencer G1/4

Flying connectors/connections table

TSCF000

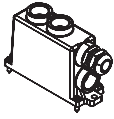

■ female connector
25 poles D-sub
without cable

TSCF24S0300
TSCF24S0500
TSCF24S1000

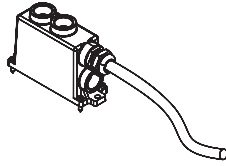

■ flying female connector sub D
according to CEI 20-22 O.R. II
(upon request)
prewired for 24 coils
M3 x 12 fixing screws

TSCF16D0300
TSCF16D0500
TSCF16D1000

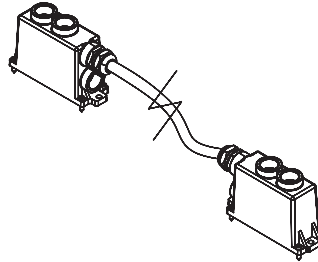

■ flying male/female connector sub D
according to CEI 20-22 O.R. II
(upon request)
prewired for 24 coils
with cable Ø8 mm (3-5-10 m length)
suitable for mobile lying
M3 x 12 fixing screws

➤ Colour identification according to standard DIN 47100

Female connector D-SUB 25 poles
for 12+12 coils

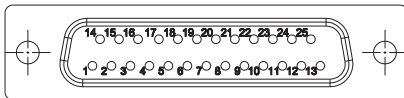

PIN N°	Operator side	Valve N°	TSCF16D		TSCF24S	
			Colour	Coil	Colour	Coil
1	14	1	white	coil 1	white	coil 1
2	12	1	brown	coil 2	brown	coil 2
3	14	2	green	coil 3	green	coil 3
4	12	2	grey	coil 4	yellow	coil 4
5	14	3	pink	coil 5	grey	coil 5
6	12	3	blue	coil 6	pink	coil 6
7	14	4	violet	coil 7	blue	coil 7
8	12	4	grey-pink	coil 8	red	bobina8
9	14	5	red-blue	coil 9	black	bobina9
10	12	5	white-green	coil 10	violet	coil 10
11	14	6	brown-green	coil 11	grey-pink	coil 11
12	12	6	white-yellow	coil 12	red-blue	coil 12
13	14	7	yellow-brown	coil 13	white-green	coil 13
14	12	7	white-grey	coil 14	brown-green	coil 14
15	14	8	grey-brown	coil 15	white-yellow	coil 15
16	12	8	white-pink	coil 16	yellow-brown	coil 16
17	14	9	white-brown	not used	white-grey	coil 17
18	12	9	white-blue	not used	grey-brown	coil 18
19	14	10	black	com 0V	white-pink	coil 19
20	12	10	black	com 0V	pink-brown	coil 20
21	14	11	red	24V INP	white-blue	coil 21
22	12	11	red	24V INP	brown-blue	coil 22
23	14	12	yellow	com 0V	white-red	coil 23
24	-	-	yellow	com 0V	brown-red	com 0V
					brown-black	com 0V
					shield	shield
25	12	12	shield	shield	white-black	coil 24