

HZE

Air treatment units

- HZE0 - G1/4 (40 mm)
- HZE05 - G1/4 - G3/8 (50 mm)
- HZE1 - G3/8 - G1/2 (63 mm)
- HZE2 - G1/2 (80 mm)

Standard configurations

- Filter (F)
- Regulator (R)
- Lubricator (L)
- Filter regulator (FR)
- Filter regulator + Lubricator (FR+L)
- Filter + Regulator + Lubricator (F+R+L)

Integrated square pressure gauge standard supplied (where foreseen)

Available ATEX version upon request

CE II 3 GD c nA II T5 -10°C ≤ Ta ≤ 45°C

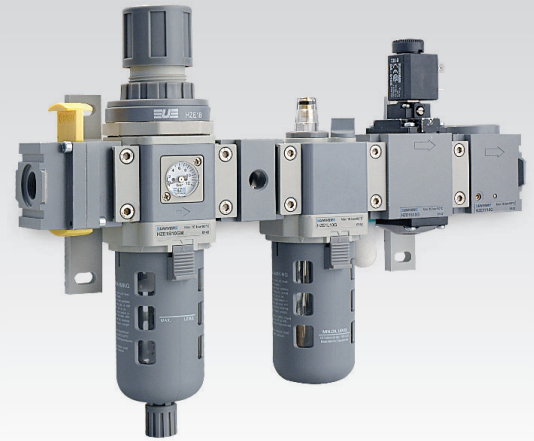

TECHNICAL CHARACTERISTICS

Ambient temperature	0 ÷ 60 °C
Fluid	filtered air, with or without lubrication
Working pressure	0 ÷ 10 bar
Max pressure	15 bar
Size	0 - 05 - 1 - 2

CONSTRUCTIVE CHARACTERISTICS

Body	tecnopolymer with metal threaded elements (size 0) die-cast aluminium (size 05 - 1 - 2)
Knob	tecnopolymer
Ring nut	tecnopolymer
Bowl	polycarbonate
Bowl guard	tecnopolymer (size 05 - 1 - 2)
Filter element	polyethylene
Seals	nitrile rubber (NBR)
Springs	steel
Diaphragm	fabric reinforced rubber

CODIFICATION KEY

H	Z	E	0	B	0	8	G		M	
1	2	3	4	5	6	7				

1 Series	2 Size	3 Model	4 Connection
HZE = Air treatment units with standard manual drain	0 = Small (G1/4) 05 = Intermediate (G1/4 - G3/8) 1 = Medium (G3/8 - G1/2) 2 = Large (G1/2)	F = Filter (F) R = Regulator (R) L = Lubricator (L) B = Filter regulator D = Filter regulator+Lubricator (FR+L) C = Filter+Regulator+Lubricator (F+R+L)	08G = G1/4 (tg.0) 10G = G3/8 (tg.1) 15G = G1/2 (tg.1 - 2) 20G = G3/4 (tg. 2) * 25G = G1 (tg. 2) * * = with threaded ends
5 Option	6 Pressure gauge	7 ATEX Option	
A = Automatic drain (except for size 0) S = Semi-automatic drain	M = Integrated square pressure gauge (standard supplied) Square adaptor G1/8 upon request	X = ATEX (upon request) See ATEX Catalogue for types and versions	

For round gauge mounting (HZ9P):

Size 0-05 = Replace HZ9464G gauge with HZE7Z480 square adaptor G1/8, to be ordered separately

Size 1-2 = Replace HZ9464G gauge with HZE7Z480 square adaptor G1/8 placed on the rear side of the regulator or filter regulator

Flow rate characteristics

Filter

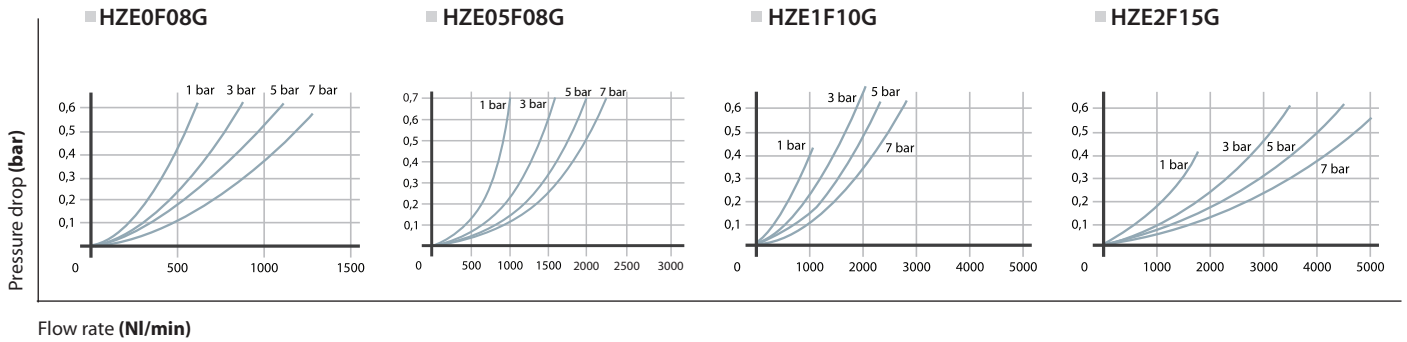

Regulator

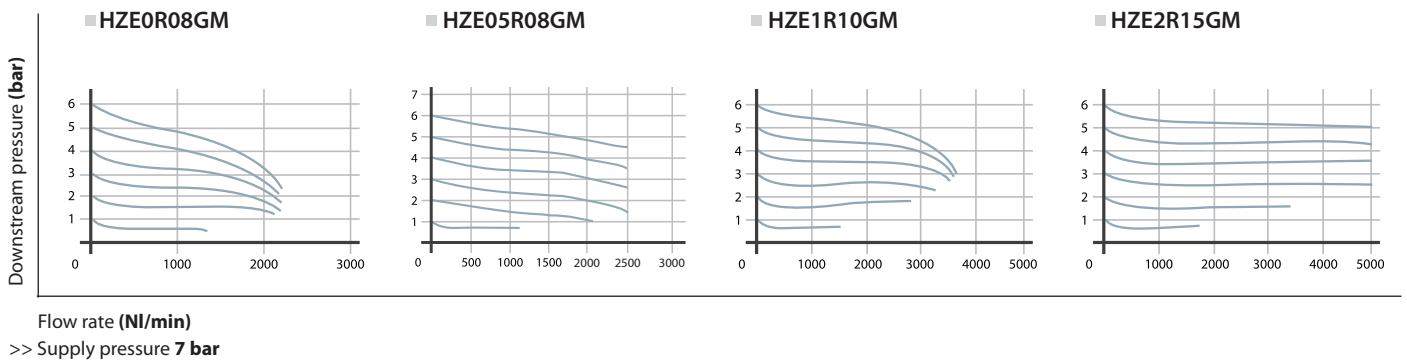

Lubricator

4

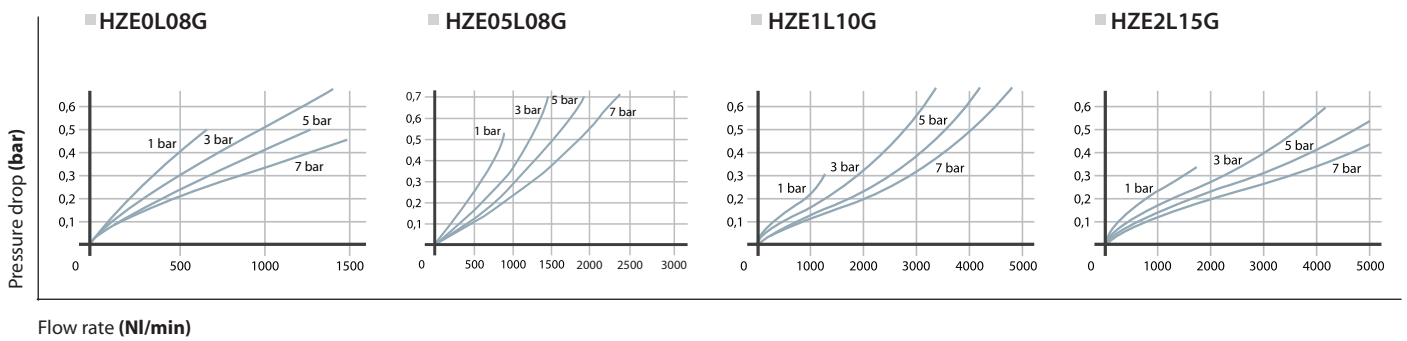

Filter regulator

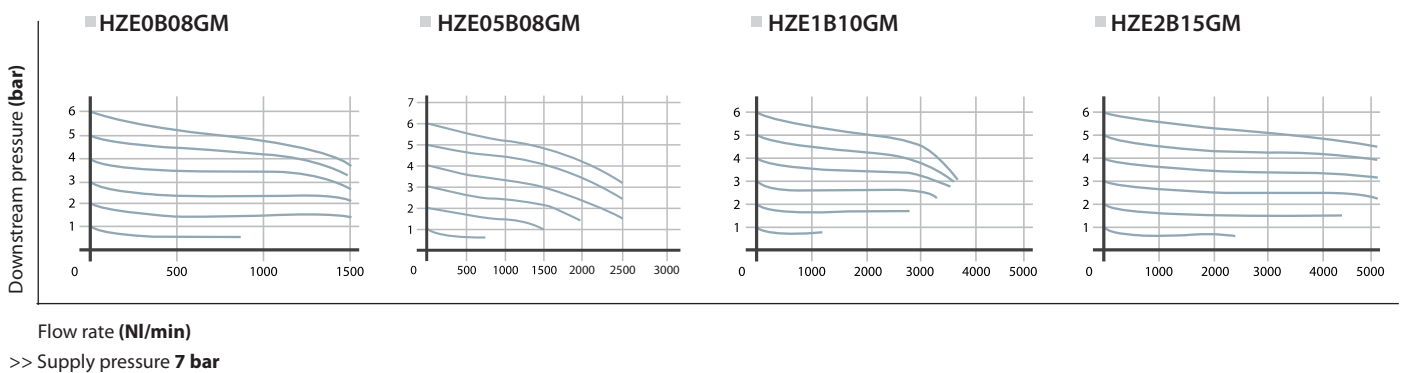

Filter	Size					
	0	05		1	2	
Part no.	HZE0F08G	HZE05F08G	HZE05F10G	HZE1F10G	HZE1F15G	HZE2F15G
Connections	G1/4	G1/4	G3/8	G3/8	G1/2	G1/2
Filtration rating (µm)	5	5		5		5
Nominal flow rate (NI/min) ^(A)	1100	1500	2000	2300	2500	5000
Max supply pressure (bar-MPa-psi)	10 - 1 - 145		10 - 1 - 145		10 - 1 - 145	
Fluid	compressed air		compressed air		compressed air	
Ambient temperature (°C)	0 ÷ 60		0 ÷ 60		0 ÷ 60	
Condensation drain capacity (cm ³)	12		40		80	
Condensation drain	manual		manual		manual	
Weight (Kg)	0,10		0,17		0,31	
Mounting position	vertical		vertical		vertical	

(A) = supply pressure 7 bar - Δp 0,5 bar

Size 0

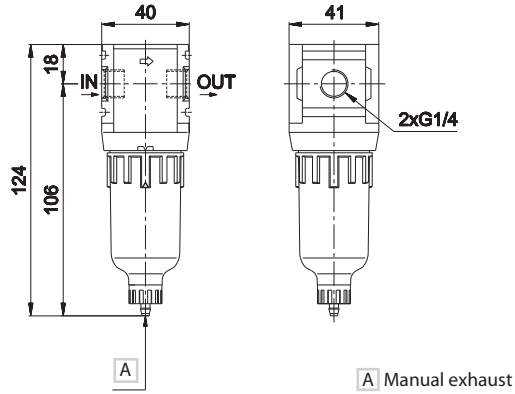

Size 05

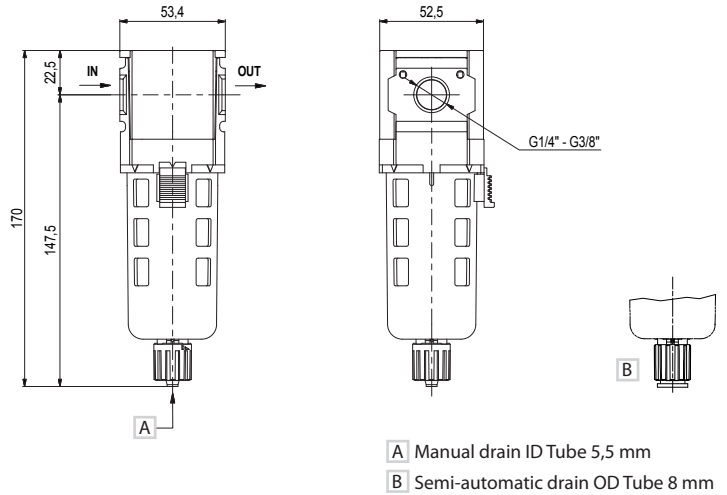

Size 1 - 2

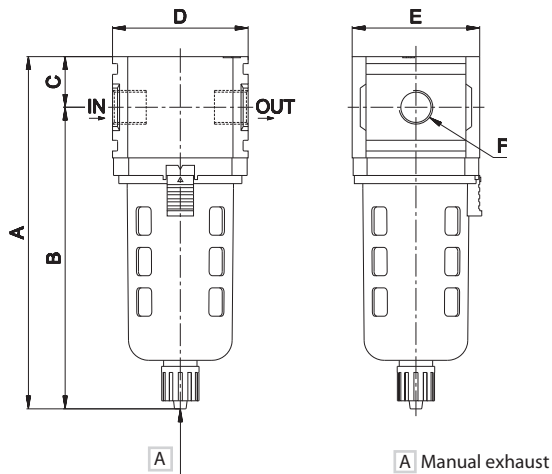

Size	A	B	C	D	E	F
1	180	157	23	63	63	G3/8-G1/2
2	195	172	23	80	80	G1/2

Regulator	Size					
	0	05		1	2	
Part no.	HZE0R08GM	HZE05R08GM	HZE05R10GM	HZE1R10GM	HZE1R15GM	HZE2R15GM
Connections	G1/4	G1/4	G3/8	G3/8	G1/2	G1/2
Nominal flow rate (NI/min) ^(A)	1000	1900	2500	2800	3500	5000
Max supply pressure (bar-MPa-psi)	10 - 1 - 145	10 - 1 - 145		10 - 1 - 145		10 - 1 - 145
Pressure adjustment relieving (bar)	0,5 ÷ 8,5	0,5 ÷ 8,5		0,5 ÷ 8,5		0,5 ÷ 8,5
Pressure gauge (standard supplied)	HZ9464G	HZ9464G		HZ9464G		HZ9464G
Pressure gauge port	G1/8 ^(B)	G1/8 ^(B)		G1/8 ^(C)		G1/8 ^(C)
Fluid	filtered air	filtered air		filtered air		filtered air
Ambient temperature (°C)	0 ÷ 60	0 ÷ 60		0 ÷ 60		0 ÷ 60
Weight (Kg)	0,16	0,31		0,45		0,70
Mounting position	any	any		any		any

(A) = supply pressure 7 bar, outlet pressure 5 bar - Δp 1 bar

(B) = upon request (replace HZ9464G gauge with HZE7Z480 square adaptor G1/8, to be ordered separately)

(C) = standard supplied (replace HZ9464G gauge with HZE7Z480 square adaptor G1/8 placed on the rear side)

Size 0

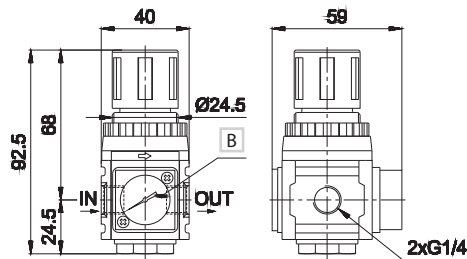
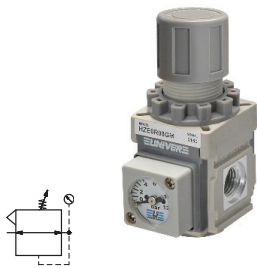

B HZ9464G gauge standard supplied

Size 05

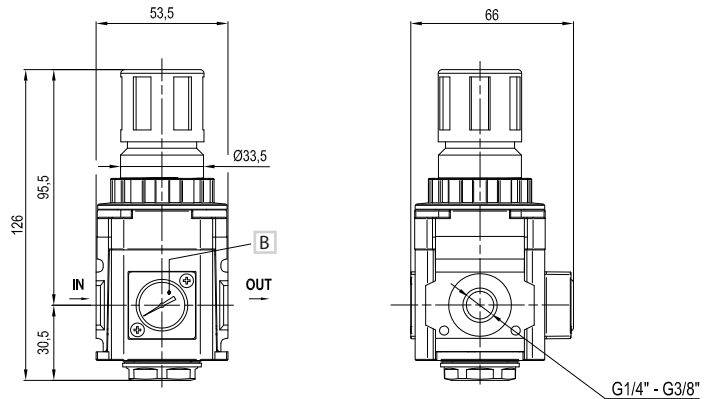

B HZ9464G gauge standard supplied

Size 1 - 2

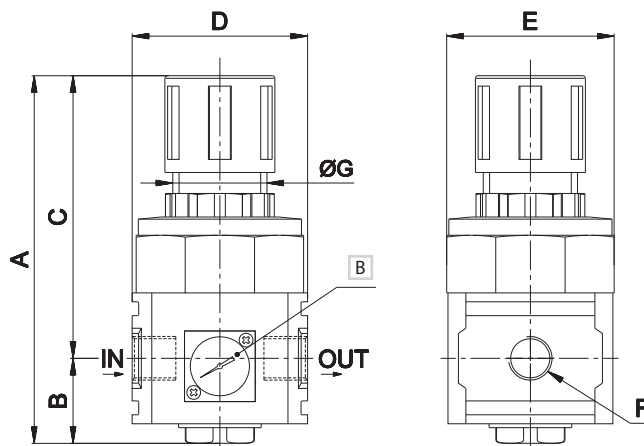

B HZ9464G gauge standard supplied

Size	A	B	C	D	E	F	G
1	136	32,5	103,5	63	63	G3/8-G1/2	35
2	145	34,5	110,5	80	80	G1/2	40

Lubricator	Size					
	0	05		1	2	
Part no.	HZE0L08G	HZE05L08G	HZE05L10G	HZE1L10G	HZE1L15G	HZE2L15G
Connections	G1/4	G1/4	G3/8	G3/8	G1/2	G1/2
Nominal flow rate (NI/min) (A)	1400	1800	3800	4400		7000
Max supply pressure (bar-MPa-psi)	10-1-145	10-1-145		10-1-145		10-1-145
Fluid	filtered air	filtered air		filtered air		filtered air
Ambient temperature (°C)	0 ÷ 60	0 ÷ 60		0 ÷ 60		0 ÷ 60
Bowl capacity (cm³)	20	70		85		170
Weight (Kg)	0,10	0,21		0,31		0,46
Mounting position	vertical	vertical		vertical		vertical
Recommended oil	ISO VG 32	ISO VG 32		ISO VG 32		ISO VG 32
Minimum working flow (l/min)	15	30		30		65

(A) = supply pressure 7 bar - Δp 0,5 bar

Size 0

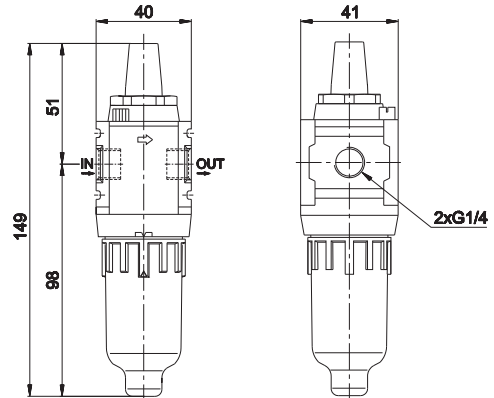

Size 05

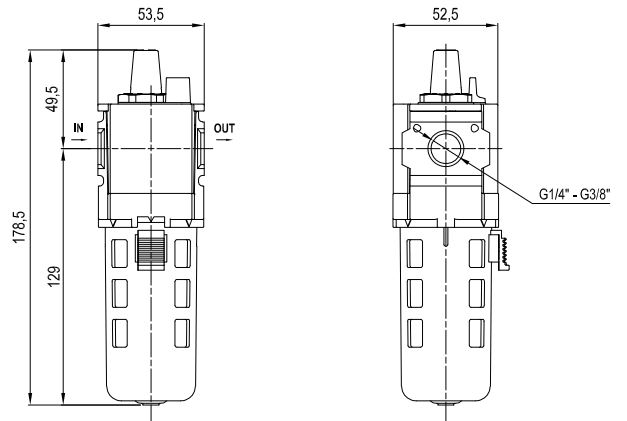

Size 1 - 2

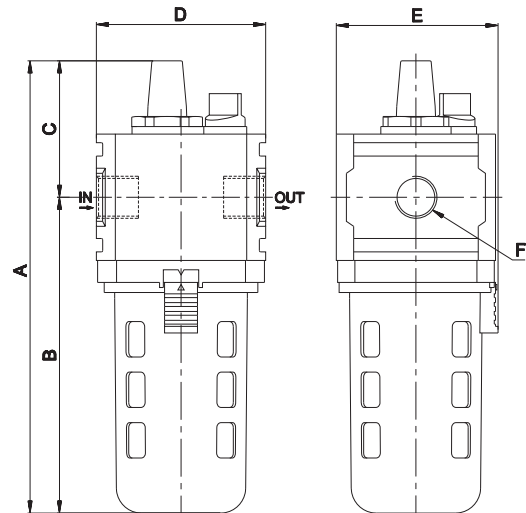

Size	A	B	C	D	E	F
1	182,5	130	52,5	63	63	G3/8-G1/2
2	201,5	148	53,5	80	80	G1/2

Filter regulator	Size					
	0	05		1	2	
Part no.	HZE0B08GM	HZE05B08GM	HZE05B10GM	HZE1B10GM	HZE1B15GM	HZE2B15GM
Connections	G1/4	G1/4	G3/8	G3/8	G1/2	G1/2
Filtration rating (µm)	5	5		5		5
Nominal flow rate (NI/min) ^(A)	600	1500	2000	2500	3000	4500
Max supply pressure (bar-MPa-psi)	10-1-145		10-1-145		10-1-145	
Pressure adjustment by relieving (bar)	0,5 ÷ 8,5		0,5 ÷ 8,5		0,5 ÷ 8,5	
Pressure gauge (standard supplied)	HZ9464G		HZ9464G		HZ9464G	
Pressure gauge port	G1/8 ^(B)	G1/8 ^(B)		G1/8 ^(C)		G1/8 ^(C)
Fluid	compressed air		compressed air		compressed air	
Ambient temperature (°C)	0 ÷ 60		0 ÷ 60		0 ÷ 60	
Condensation drain capacity (cm ³)	12		40		45	
Condensation drain	manual		manual		manual	
Weight (Kg)	0,21		0,41		0,65	
Mounting position	vertical		vertical		vertical	

(A) = supply pressure 7 bar, outlet pressure 5 bar - Δp 1 bar

(B) = Upon request (replace HZ9464G gauge with HZE7Z480 square adaptor G1/8, to be ordered separately)

(C) = Standard supplied (replace HZ9464G gauge with HZE7Z480 square adaptor G1/8 placed on the rear side)

Size 0

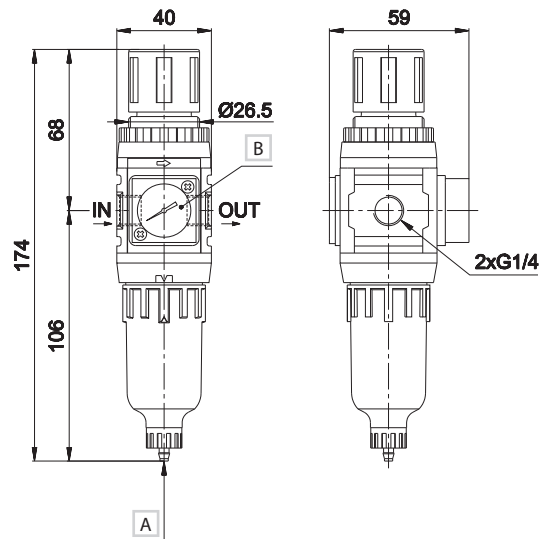

- A Manual exhaust
- B HZ9464G gauge standard supplied

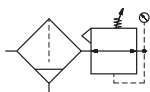

Size 05

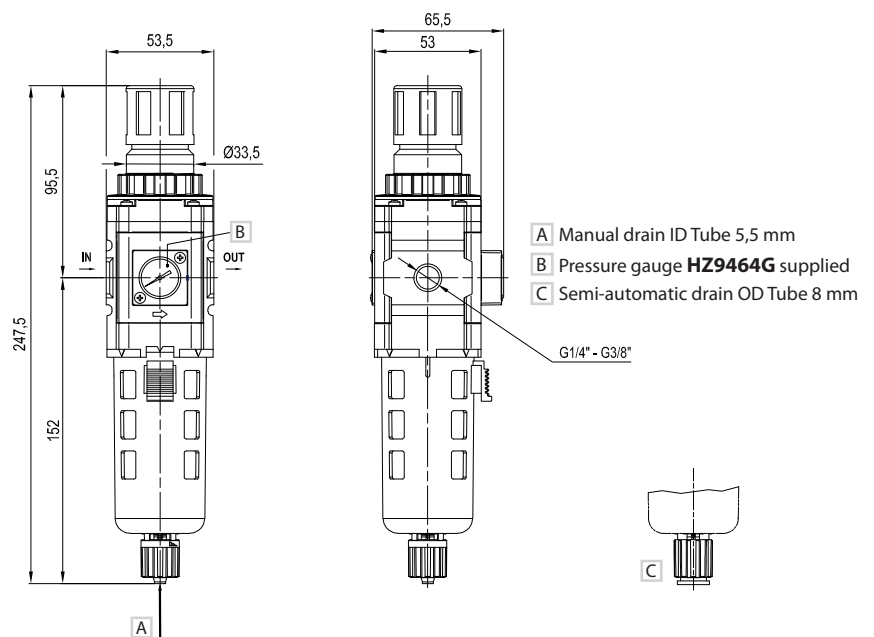

- A Manual drain ID Tube 5,5 mm
- B Pressure gauge HZ9464G supplied
- C Semi-automatic drain OD Tube 8 mm

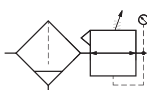

4

Size 1 - 2

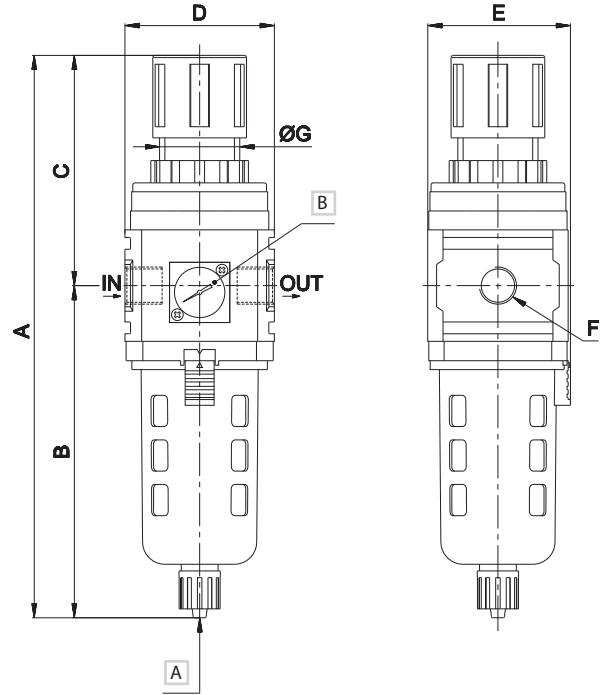
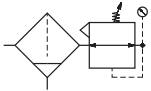

A Manual exhaust

B HZ9464G gauge standard supplied

Size	A	B	C	D	E	F	G
1	259	156	103	63	63	G3/8-G1/2	40
2	280	170	110	80	80	G1/2	47

Filter regulator + Lubricator	Size					
	0	05		1	2	
Part no.	HZE0D08GM	HZE05D08GM	HZE05D10GM	HZE1D10GM	HZE1D15GM	HZE2D15GM
Connections	G1/4	G1/4	G3/8	G3/8	G1/2	G1/2
Filtration rating (µm)	5	5		5		5
Nominal flow rate (NI/min) (A)	600	1500	2000	2500	2800	4300
Max supply pressure (bar-MPa-psi)	10-1-145		10-1-145		10-1-145	
Pressure adjustment by relieving (bar)	0,5 ÷ 8,5		0,5 ÷ 8,5		0,5 ÷ 8,5	
Pressure gauge (standard supplied)	HZ9464G		HZ9464G		HZ9464G	
Pressure gauge port	G1/8 ^(B)		G1/8 ^(B)		G1/8 ^(C)	
Fluid	compressed air		compressed air		compressed air	
Ambient temperature (°C)	0 ÷ 60		0 ÷ 60		0 ÷ 60	
Condensation drain capacity (cm ³)	12		40		45	
Condensation drain	manual		manual		manual	
Weight (Kg)	0,33		0,70		1,05	
Mounting position	vertical		vertical		vertical	
Recommended oil	ISO VG 32		ISO VG 32		ISO VG 32	
Minimum working flow (l/min)	15		30		30	

(A) = supply pressure 7 bar, outlet pressure 5 bar - Δp 1 bar

(B) = upon request (replace HZ9464G gauge with HZE7Z480 square adaptor G1/8, to be ordered separately)

(C) = standard supplied (replace HZ9464G gauge with HZE7Z480 square adaptor G1/8 placed on the rear side)

Size 0

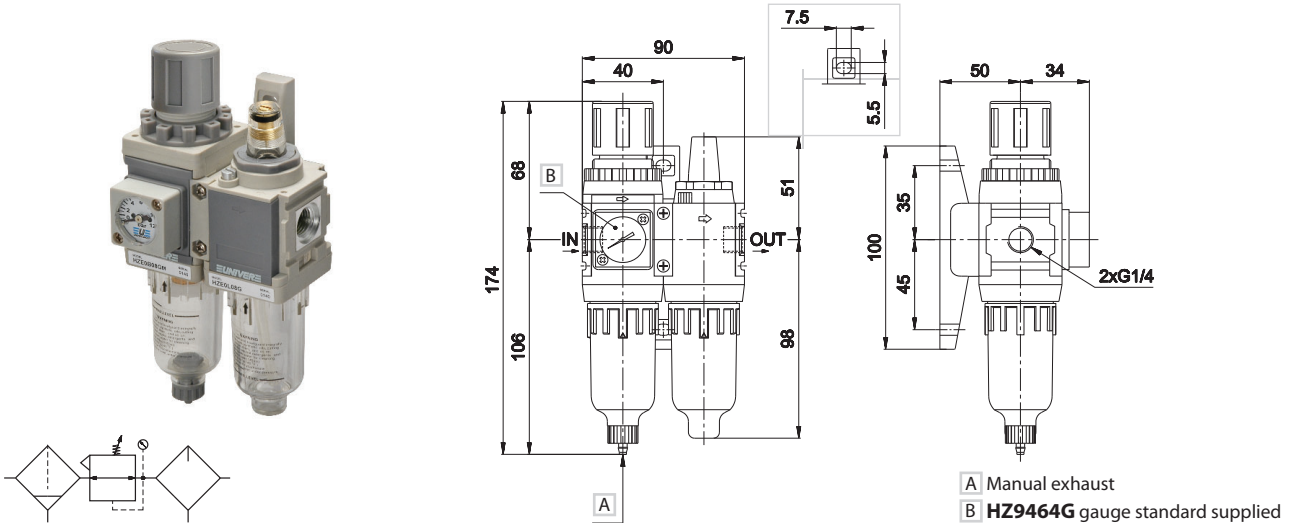

Size 05

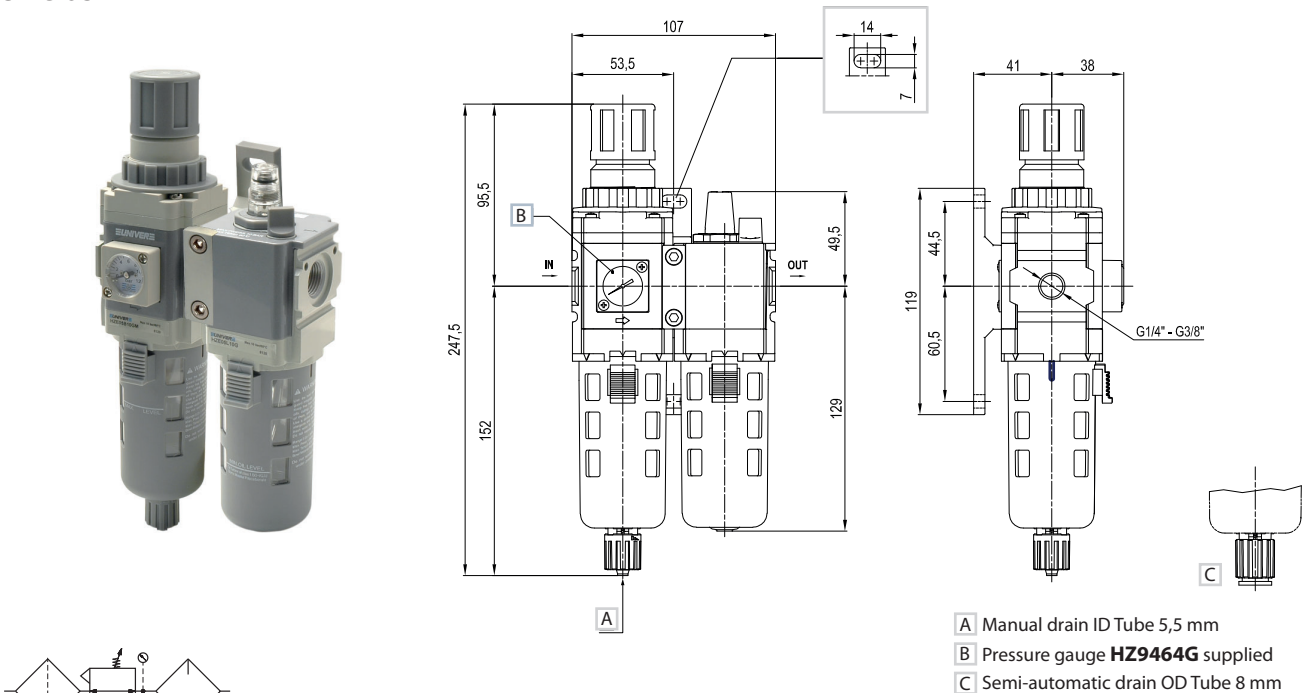

4

Size 1 - 2

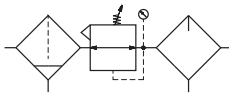
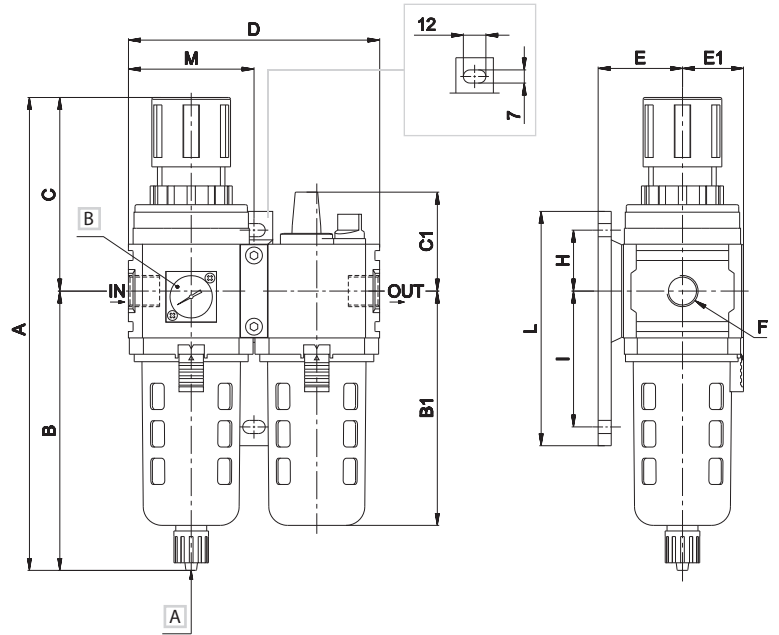

- A Manual exhaust
- B HZ9464G gauge standard supplied

Size	A	B	B1	C	C1	D	E	E1	F	H	I	L	M
1	259	156	130	103	52,5	126	45	31,5	G3/8-G1/2	45	60	125	63
2	280	170	148	110	53,5	160	55	40	G1/2	45	60	125	80

Filter + Regulator + Lubricator	Size					
	0	05		1	2	
Part no.	HZE0C08GM	HZE05C08GM	HZE05C10GM	HZE1C10GM	HZE1C15GM	HZE2C15GM
Connections	G1/4	G1/4	G3/8	G3/8	G1/2	G1/2
Filtration rating (µm)	5	5		5		5
Nominal flow rate (NI/min) ^(A)	550	1300	1500	1800	2000	3000
Max supply pressure (bar-MPa-psi)	10-1-145	10-1-145		10-1-145		10-1-145
Pressure adjustment by relieving (bar)	0,5 ÷ 8,5	0,5 ÷ 8,5		0,5 ÷ 8,5		0,5 ÷ 8,5
Pressure gauge (standard supplied)	HZ9464G	HZ9464G		HZ9464G		HZ9464G
Pressure gauge port	G1/8 ^(B)	G1/8 ^(B)		G1/8 ^(C)		G1/8 ^(C)
Fluid	compressed air	compressed air		compressed air		compressed air
Ambient temperature (°C)	0 ÷ 60	0 ÷ 60		0 ÷ 60		0 ÷ 60
Condensation drain capacity (cm ³)	12	40		45		80
Condensation drain	manual	manual		manual		manual
Weight (Kg)	0,40	0,80		1,25		1,90
Mounting position	vertical	vertical		vertical		vertical
Recommended oil	ISO VG 32	ISO VG 32		ISO VG 32		ISO VG 32
Minimum working flow (l/min)	15	30		30		65

(A) = supply pressure 7 bar, outlet pressure 5 bar - Δp 1 bar

(B) = optional (replace HZ9464G gauge with G1/8 adaptor HZE7Z480 to be ordered separately)

(C) = standard (replace HZ9464G gauge with G1/8 adaptor HZE7Z480 placed on the back side)

Size 0

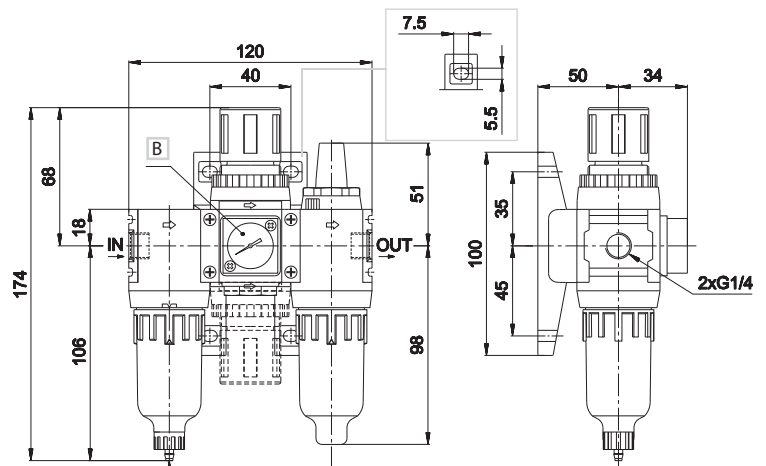
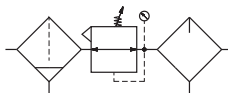

- A Manual exhaust
- B HZ9464G gauge standard supplied

Size 05

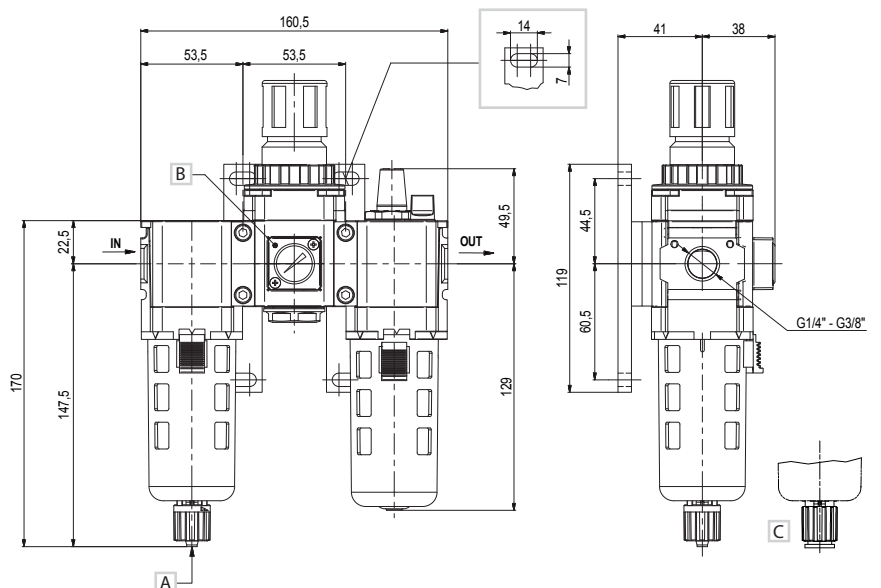
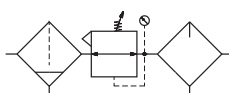

- A Manual drain ID Tube 5,5 mm
- B Pressure gauge HZ9464G supplied
- C Semi-automatic drain OD Tube 8 mm

Size 1 - 2

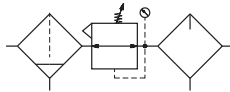
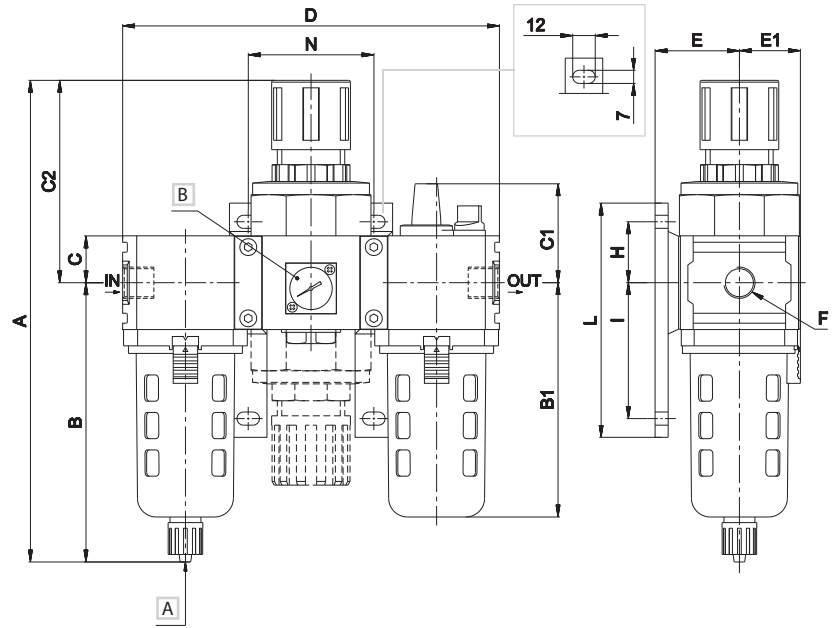

- A Manual exhaust
- B HZ9464G gauge standard supplied

Size	A	B	B1	C	C1	C2	D	E	E1	F	H	I	L	N
1	260,5	157	130	23	52,5	103,5	190	45	31,5	G3/8-G1/2	45	60	125	63
2	282,5	172	148	23	53,5	110,5	240	55	40	G1/2	45	60	125	80

Other versions available

HZE...G



Regulator without manometer
size 0 - 05
size 0 HZE0R08G
size 05 HZE05R08G - HZE05R10G

HZE...GM



Regulator with lockable knob
size 05 - 1 - 2
size 05 HZE05RL08GM - HZE05RL10GM
size 1 HZE1RL10GM - HZE1RL15GM
size 2 HZE2RL15GM

HZE...GMV

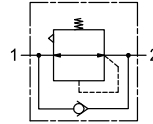

Regulator with check valve
size 0 - 05 - 1 - 2
The check valve inside the regulator allows to relieve downstream pressure in a quick and effective way.
size 0 HZE0R08GMV
size 05 HZE05R08GMV - HZE05R10GMV
size 1 HZE1R10GMV - HZE1R15GMV
size 2 HZE2R15GMV

HZE...GQ/GT



Regulator with integrated digital pressure switch
size 0 - 05 - 1 - 2
size 0 HZE0R08GQ
size 05 HZE05R08GQ - HZE05R10GQ
size 1 HZE1R10GQ - HZE1R15GQ
size 2 HZE2R15GQ

GT Version
Integrated digital pressure M8 connection

HZE...GMV

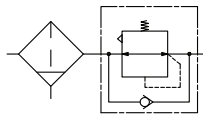

Filter regulator with check valve
size 0 - 05 - 1 - 2
The check valve inside the filter regulator allows to relieve downstream pressure in a quick and effective way.
size 0 HZE0B08GMV
size 05 HZE05B08GMV - HZE05B10GMV
size 1 HZE1B10GMV - HZE1B15GMV
size 2 HZE2B15GMV

HZE...GQ/GT



Filter regulator with integrated digital pressure switch
size 0 - 05 - 1 - 2
size 0 HZE0B08GQ
size 05 HZE05B08GQ - HZE05B10GQ
size 1 HZE1B10GQ - HZE1B15GQ
size 2 HZE2B15GQ

GT Version
Integrated digital pressure switch M8 connection

4

Gradual Starter	Size		
	0		1*
Part no.	HZE0Y08G	HZE1Y10G	HZE1Y15G
Connections	G1/4	G3/8	G1/2
Nominal flow rate (NI/min) ^(A)	900		2200
Max supply pressure (bar-MPa-psi)	10-1-145		10-1-145
Min. pressure (bar)	2		3,5
Fluid	compressed air		compressed air
Ambient temperature (°C)	-20 ÷ 80		-20 ÷ 80
Weight (Kg)	0,30		0,49
Mounting position	vertical		vertical

(A) = supply pressure 7 bar, outlet pressure 5 bar - Δp 1 bar

* = Suitable also for size 05 and 2

The gradual starter is used in pneumatic circuits where a cut-off in pressure or an abrupt start-up is to be avoided to prevent possible damages to equipment.

FUNCTIONING PRINCIPLE

2 way valve which, in the stand-by position, allows the passage of an air regulated flow, when the working pressure is reached the valve allows the air full passage.

Size 0 - 1

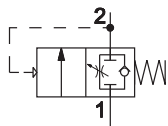
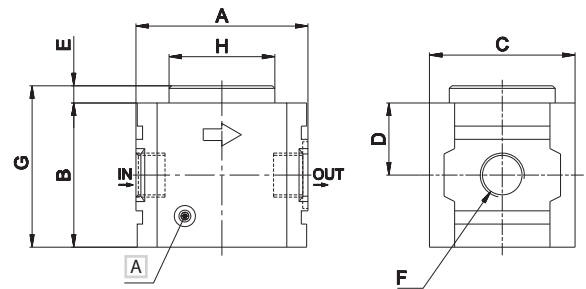

A Regulation

Size	A	B	C	D	E	F	G	Ø H
0	55	55	40	27,5	6,5	G1/4	61,5	40
1	65	54,5	55	22,25	6,5	G3/8-G1/2	61	40

Diverter Block	Size			
	0	1*		
Part no.	HZE0N08G	HZE1N10G	HZE1N15G	HZE1N1006G
Connections (A)	In/Out G1/4 Auxiliary G1/8	In/Out G3/8	In/Out G1/2	- Auxiliary G1/8 - G3/8
Max supply pressure (bar-MPa-psi)	10-1-145	10-1-145	10-1-145	10-1-145
Fluid	compressed air	compressed air	compressed air	compressed air
Ambient temperature (°C)	0 ÷ 60	0 ÷ 60	0 ÷ 60	0 ÷ 60
Weight (Kg)	0,12	0,23	0,27	0,27
Mounting position	vertical	vertical	vertical	vertical

(A) = Use blanking plugs to close unused ways

* = Suitable also for size 05 and 2

Threaded ports on each side. Possibility to assembly pressure switch.

Size 0 - 1

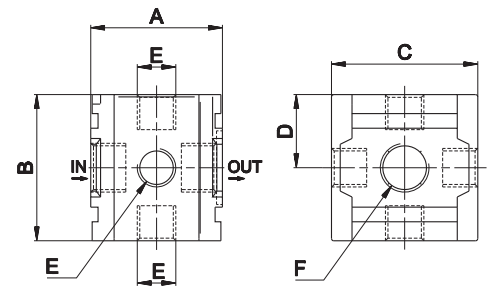

Size	A	B	C	D	E	F	Part no.
0	28	36	34	18	G1/8	G1/4	HZE0N08G
1	45	50	50	25	G1/4	G3/8	HZE1N10G
						G1/2	HZE1N15G

Ports

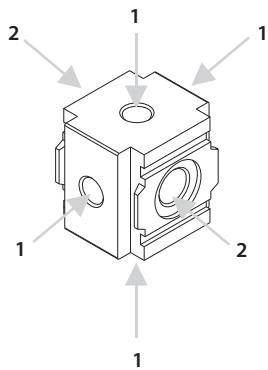

1 = Auxiliary
2 = Inlet-Outlet

Size 1 - Intermediate diverter block

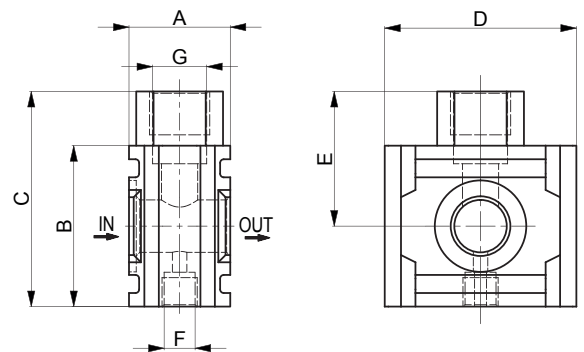

Size	A	B	C	D	E	F	G	Part no.
1	28	45	59	53	37	G 1/8	G 3/8	HZE1N1006G

Lockable Valve	Size		
	0	HZE1P10G	1*
Part no.	HZE0P08G	HZE1P10G	HZE1P15G
Connections	G1/4	G3/8	G1/2
Nominal flow rate (NI/min) ^(A)	900		5000
Max supply pressure (bar-MPa-psi)	10-1-145		10-1-145
Fluid	compressed air		compressed air
Ambient temperature (°C)	0 ÷ 60		0 ÷ 60
Weight (Kg)	0,21		0,28
Mounting position	vertical		vertical

(A) = supply pressure 7 bar, outlet pressure 5 bar - Δp 1 bar

* = Suitable also for size 05 and 2

The lockable valve is a 3-way 2-position manual valve. In the closed position it enables discharge of the downstream system of the air preparation equipment. By using one or two locks (not included) the user is not allowed to pressurize the system accidentally.

Size 0

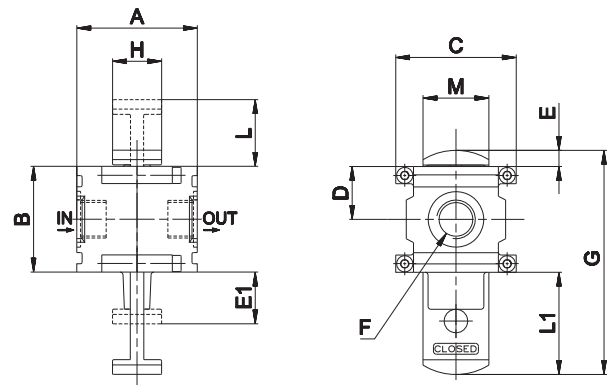

Size 1

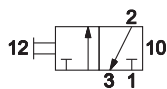
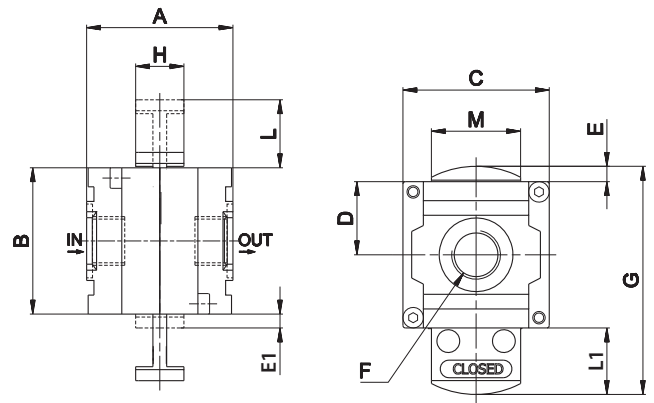
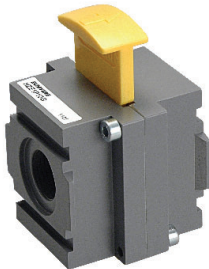

Size	A	B	C	D	E	E1	F	G	H	L	L1	M
0	41	36	41	18	6	18	G1/4	75,5	17	21,5	35	22,5
1	50	50	50,5	25	5	5	G3/8-G1/2	78	16,5	23	23	30,5

Shut-off valve	Size		
	0		1*
Part no.	HZE0S08G	HZE1S10G	HZE1S15G
Connections	G1/4	G3/8	G1/2
Nominal flow rate (NI/min) ^(A)	900		2800
Exhaust flow rate (NI/min)	1100		1500
Max supply pressure (bar-MPa-psi)	10-1-145		10-1-145
Min pressure (bar-MPa-psi)	2 - 0,16 - 23		2 - 0,2 - 29
Fluid	compressed air		compressed air
Ambient temperature (°C)	5 ÷ 60		5 ÷ 60
Weight (Kg)	0,46		0,7
Mounting position	vertical		vertical
Commutation system	poppet valve		poppet valve
Ways/Position	3/2 NC		3/2 NC
Control	indirect electropneumatic control		indirect electropneumatic control
Nominal diameter	8		10
Electropilot	U1 AA series		
Coil	DA/DC		
Power consumption	3,5 W (DC) - 5 VA (AC)		
Electrical connection	AM-5110		
Voltage	12 V DC - 24 V DC - 24 V AC - 110 V AC - 230 V AC		
Manual Override	with 2-position screw		

(A) = supply pressure 7 bar, outlet pressure 5 bar - Δp 1 bar
 * = Suitable also for size 05 and 2

The 3-ways valve enable system supply and exhaust.
 Version with CNOMO or 15 mm electropilot is available upon request.

Size 0

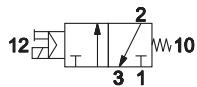

- A Manual override
- B Exhaust

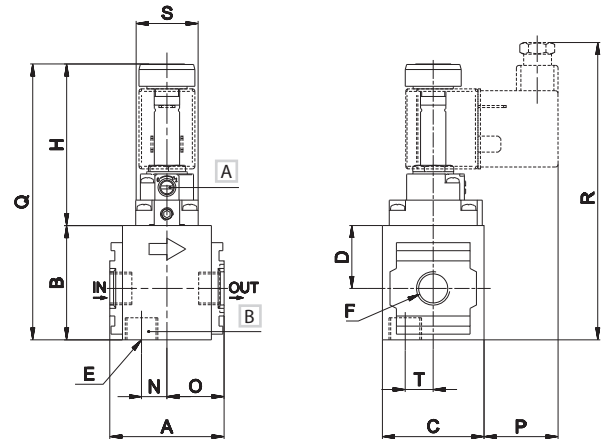

Size 1

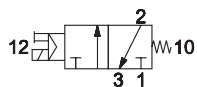

- A Manual override
- B Exhaust

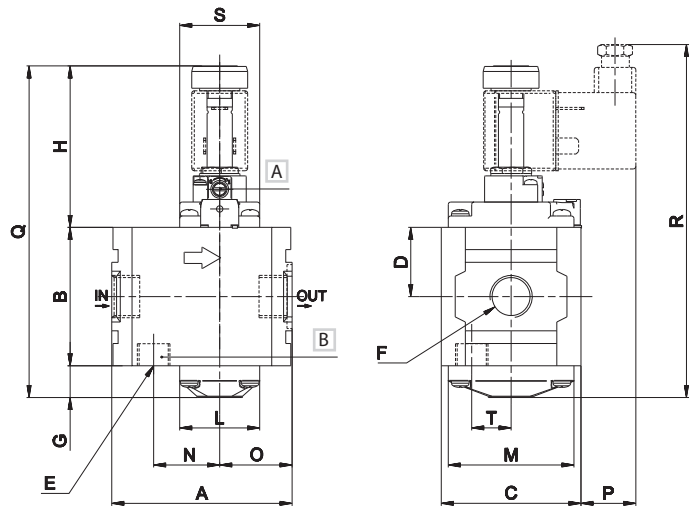

Size	A	B	C	D	E	F	G	H	ØL	ØM	N	O	P	Q	R	S	T
0	45	45	40	25	G1/4	G1/4	-	64	-	-	10	22,5	29	109	117	24,5	11
1	71	54,5	55	27	G1/4	G3/8-G1/2	12,5	64	32	49,5	26	29	22	131	139	31,5	15,5

Solenoid valves are supplied with locking nut, without coil

Other versions available

Coils for Shut-off valves

U05 U3 CNOMO

U1 U3



Size 0 Size 1 * Size 1 *
 * = Suitable also for size 05 and 2

DA-0050 12 V DC
 DA-0051 24 V DC
 DA-0106 24 V AC/50-60 Hz
 DA-0108 110 V AC/50-60 Hz
 DA-0124 230 V AC/50-60 Hz
 DC-0301 12 V DC
 DC-0302 24 V DC
 DC-0307 24 V AC/50-60 Hz
 DC-0309 110 V AC/50-60 Hz
 DC-0310 230 V AC/50-60 Hz

Accessories

Threaded terminals size 2

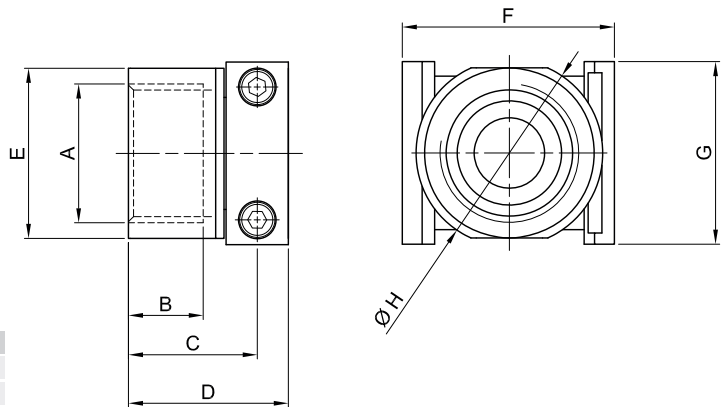
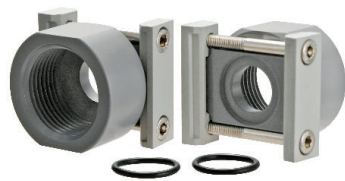

A	B	C	D	E	F	G	H	Part no.
G3/4	16	31	38,5	41	51	44	45	HZE2Z500
G1	18	31	38,5	41	51	44	45	HZE2Z501

Fixing elements

Assembly kit

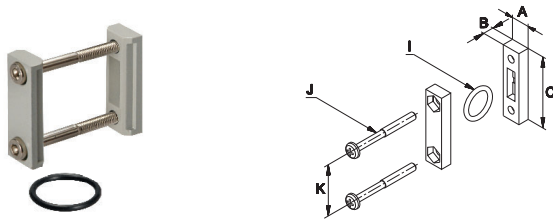

Size	A	B	C	ØI	J	K	Part no.
0	9,5	5,5	36	18	M3x37	26	HZE0Z200
05	12	7	44	25,5	M5x45	32	HZE05Z200
1	15	7	44	25,7	M5x45	32	HZE1Z200
2							



T-bracket assembly kit

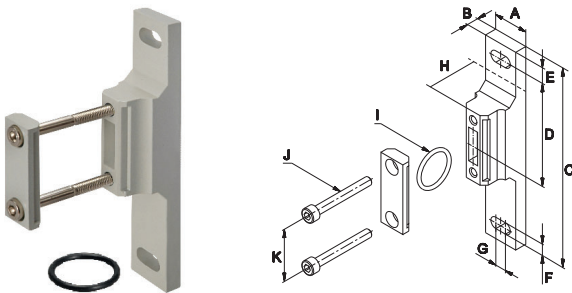

Size	A	B	C	D	E	F	G	H	ØI	J	K	Part no.
0	16	7	105	35,5	10	5,5	4	25	18	M3x37	26	HZE0Z210
05	19	6	119	44,5	7	7	7	23	25,5	M5x45	32	HZE05Z210
1	22	7	125	45	10	7	7	27	25,7	M5x45	32	HZE1Z210
2	22,5	7	125	45	10	7	7	37	25,7	M5x45	32	HZE2Z210



C-bracket

4

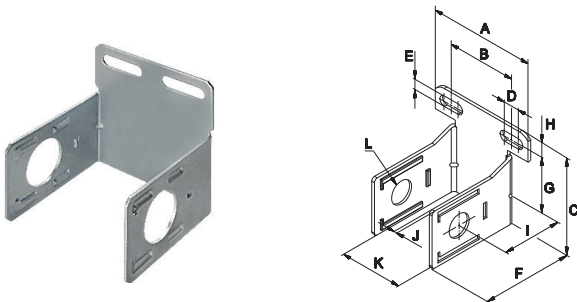

Size	A	B	C	D	E	F	G	H	I	J	K	ØL	Part no.
0	68	44	61,5	10	6,5	60	35	8,5	40	2	40	14	HZE0Z300
05	57	28	76	13	6,5	67	45	-	41	2	53,4	25,4	HZE05Z300
1	67	34,5	76	14	7	69	45	9	45	2,3	63	25	HZE1Z300
2	84	55	93,5	14	9	102	50	11	65	2,3	80	25	HZE2Z300



Regulator L-bracket

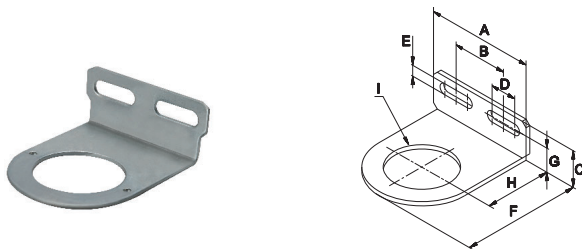

Size	A	B	C	D	E	F	G	H	ØI	Part no.
0	68	44	24,5	10	6,5	59	16	40	26,5	HZE0Z310
05	57	28	28	13	6,5	64	18	39	36,5	HZE05Z310
1	67	34,5	26	16,5	7	76	18	45	40	HZE1Z310
2	84	55	26	16,5	7	94	18	45	47	HZE2Z310



Spare parts for filter and filter regulator

HZE0/05/1/2Z600



Standard bowl with manual drain
 Size 0 HZE0Z600
 Size 05 HZE05Z600
 Size 1 HZE1Z600
 Size 2 HZE2Z600

HZE0/05/1/2Z600SS



Bowl with semi-automatic drain
 Size 0 HZE0Z600SS
 Size 05 HZE05Z600SS
 Size 1 HZE1Z600SS
 Size 2 HZE2Z600SS

HZE0/1Z401



Semi-automatic drain
 Size 0 HZE0Z401
 Size 05-1-2 HZE1Z401

HZE0/1Z402



Manual drain
 Size 0 HZE0Z402
 Size 05-1-2 HZE1Z402

HZE0/05/1/2Z660



Filter elements 5 µm
 Size 0 HZE0Z660
 Size 05 HZE05Z660
 Size 1 HZE1Z660
 Size 2 HZE2Z660

Other filter elements upon request

HZE7Z400



Automatic drain
 Size 1-2 HZE7Z400

Spare parts for regulator and filter regulator

HZE0/05/1/2Z602



Knob
 Size 0 HZE0Z602
 Size 05 HZE05Z602
 Size 1 HZE1Z602
 Size 2 HZE2Z602

HZE05/1/2Z652/4/8



Regulator spring
 Pressure adjustment:
 Size 05
 HZE05Z658 0,5 ÷ 8,5
 Size 1
 HZE1Z652 0,5 ÷ 1,7
 HZE1Z654 0,5 ÷ 3,5
 HZE1Z658 0,5 ÷ 8,5
 Size 2
 HZE2Z652 0,5 ÷ 1,7
 HZE2Z654 0,5 ÷ 3,5
 HZE2Z658 0,5 ÷ 8,5

HZE0/05/1/2Z603



Ring nut for panel
 Size 0 HZE0Z603
 Size 05 HZE05Z603
 Size 1 HZE1Z603
 Size 2 HZE2Z603

HZE0/05/1/2Z610/1



Diaphragm kit
 Size 0
 HZE0Z610 relieving
 HZE0Z611 non-relieving
 Size 05
 HZE05Z610 relieving
 HZE05Z611 non-relieving
 Size 1
 HZE1Z610 relieving
 HZE1Z611 non-relieving
 Size 2
 HZE2Z610 relieving
 HZE2Z611 non-relieving

Spare parts for lubricator

HZE0/05/1/2Z601



Standard bowl
 Size 0 HZE0Z601
 Size 05 HZE05Z601
 Size 1 HZE1Z601
 Size 2 HZE2Z601

HZE7Z470



Lubricator transparent dome
 Size 0-05-1-2 HZE7Z470

Gauges and pressure switches

HZ9P...

HZ9NPB...

HZ9PBS...

HZ9464G



Pressure gauge

Pressure gauge with flange for panel mounting

Pressure gauge with bracket for panel mounting

Recessed pressure gauge

HZ9N

HZ9NP50



Digital pressure switch

IP65 digital pressure switch with connector

For technical characteristics see Chapter 5. Accessories

HZE3

Air Treatment Units

New size 3 - G1

Standard configurations:

- Filter (F)
- Regulator (R)
- Lubricator (L)
- Filter regulator (FR)
- Filter regulator + Lubricator (FR+L)
- Filter + Regulator + Lubricator (F+R+L)



TECHNICAL CHARACTERISTICS

Ambient temperature	-5 ÷ 60 °C
Fluid	filtered compressed air, with or without lubrication
Working pressure	10 bar (pressure regulator 15 bar)
Max pressure	15 bar (pressure regulator 20 bar)

CONSTRUCTIVE CHARACTERISTICS

Body	die-cast aluminium (painted)
Knob	tecnopolymer
Ring nut	zinc-plated steel
Bowl	polycarbonate
Bowl guard	tecnopolymer
Filter element	polyethylene
Seals	nitrile rubber (NBR)
Springs	steel
Diaphragm	fabric reinforced rubber

CODIFICATION KEY

H	Z	E	3	B	2	5	G	S
1	2	3	4	5				

1 Series	2 Size	3 Model	4 Thread	5 Option
HZE = Air treatment unit with manual drain and standard semi-automatic drain	3 = G1	F = Filter (F) R = Regulator (R) L = Lubricator (L) B = Filter regulator (FR) D = Filter regulator + Lubricator (FR+L) C = Filter + Regulator + Lubricator (F+R+L)	25G = G1	A = Automatic drain S = Manual drain/semi-automatic drain (standard supplied) Excluding regulator (R) and lubricator (L)

Flow rate characteristics

Filter

■ HZE3F25GS

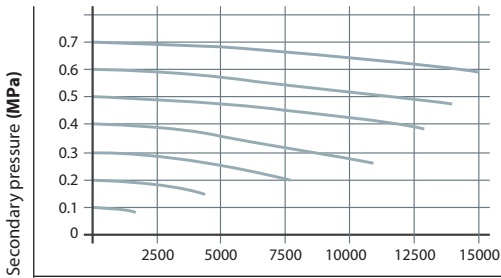

Flow rate (NI/min)

Regulator

■ HZE3R25G

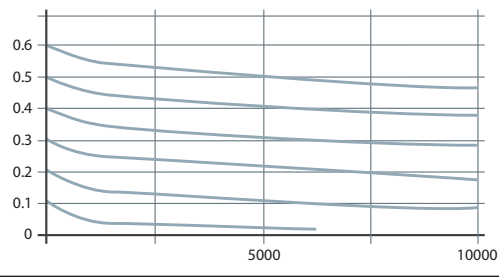

Lubricator

■ HZE3L25G

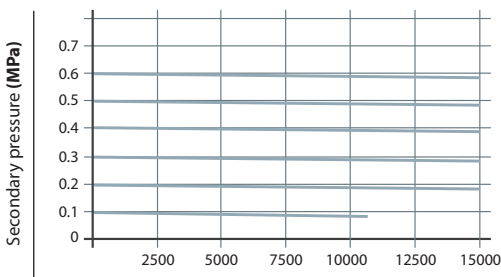

Flow rate (NI/min)

Filter regulator

■ HZE3B25GS

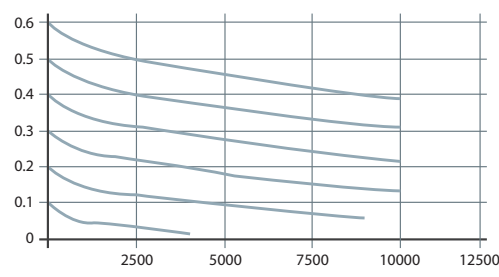

4

Filter regulator + Lubricator

■ HZE3D25GS

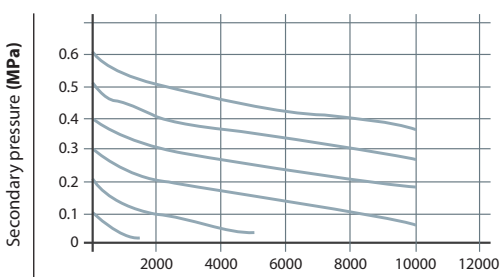

Flow rate (NI/min)

Filter + Regulator + Lubricator

■ HZE3C25GS

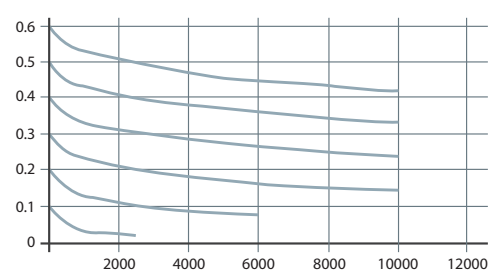

Supply pressure **7 bar**

Filter

Part no.	HZE3F25GS
Connections	G1
Filtration rate (µm)	40
Flow rate (NI/min) ^(A)	10000
Max inlet pressure (bar-MPa-psi)	10-1-145
Working pressure (bar) with manual/semi-automatic drain	0,5 ÷ 10
Working pressure (bar) with automatic drain	1,5 ÷ 10
Fluid	compressed air
Temperature (°C)	-5 ÷ 60
Condensation drain capacity (cm ³)	75
Condensation drain ^(B)	manual/semi-automatic
Weight (g)	1180
Mounting position	vertical

(A) = inlet pressure 7 bar - Δp 0,5 bar

(B) = manual drain with semi-automatic function at < 0,5 bar pressure

HZE3F25GS

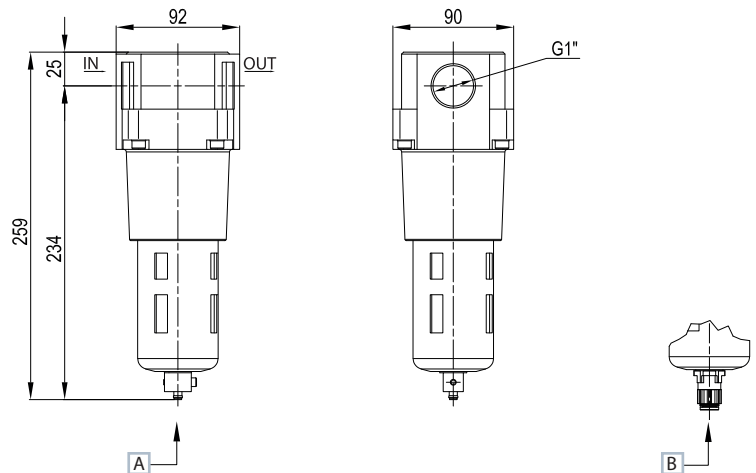

A Manual/semi-automatic drain ID Tube 6 mm

B Automatic drain OD Tube 8 mm

Regulator

Part no.	HZE3R25G
Connections	G1
Flow rate (NI/min) ^(A)	10000
Max inlet pressure (bar-MPa-psi)	15 - 1,5 - 217
Pressure adjustment - relieving version (bar)	0,5 ÷ 8,5
Pressure gauge adaptor	G1/8
Fluid	filtered air
Temperature (°C)	-5 ÷ 60
Weight (g)	1460
Mounting position	any

(A) = inlet pressure 7 bar, outlet pressure 5 bar - Δp 1 bar

HZE3Z310R L bracket, standard supplied

HZE3R25G

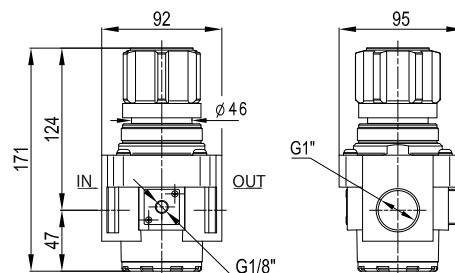

Lubricator

Part no.	HZE3L25G
Connections	G1
Flow rate (NI/min) ^(A)	10000
Max inlet pressure (bar-MPa-psi)	10-1-145
Working pressure (bar)	0,5 ÷ 10
Fluid	filtered air
Temperature (°C)	-5 ÷ 60
Bowl capacity (cm ³)	200
Weight (g)	1260
Mounting position	vertical
Recommended oil	ISO VG 32
Min. working flow rate (NI/min)	33

(A) = inlet pressure 7 bar - Δp 0,2 bar

HZE3L25G

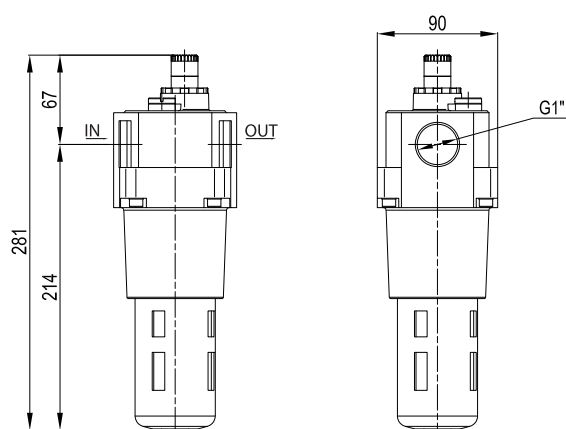

Filter regulator

Part no.	HZE3B25GS
Connections	G1
Filtration rate (µm)	40
Flow rate (NI/min) ^(A)	10000
Max inlet pressure (bar-MPa-psi)	10-1-145
Working pressure (bar) with manual/semi-automatic drain	0,5 ÷ 10
Working pressure (bar) with automatic drain	1,5 ÷ 10
Pressure adjustment - relieving version (bar)	0,5 ÷ 8,5
Pressure gauge adaptor	G1/8
Fluid	compressed air
Temperature (°C)	-5 ÷ 60
Condensation drain capacity (cm ³)	75
Drain capacity ^(B)	manual/semi-automatic
Weight (g)	1940
Mounting position	vertical

(A) = inlet pressure 7 bar, outlet pressure 5 bar - Δp 2 bar

(B) = manual drain with semi-automatic function at < 0,5 bar pressure

HZE3Z310R L bracket, standard supplied

HZE3B25G

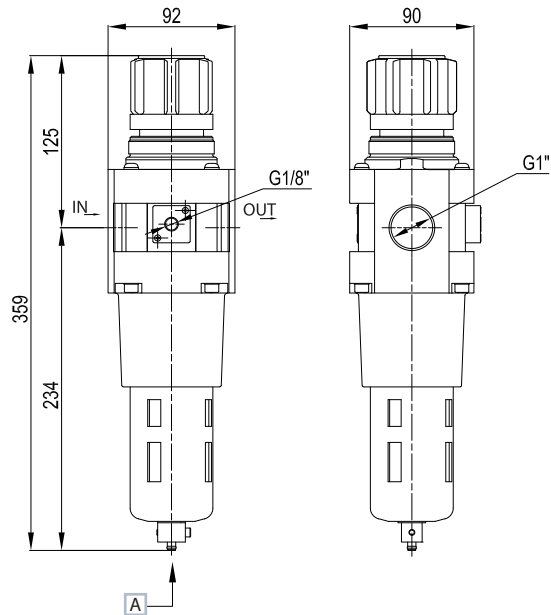
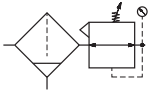

A Manual/semi-automatic drain ID Tube 6 mm

B Automatic drain OD Tube 8 mm

Filter regulator + Lubricator

Part no.	HZE3D25GS
Connections	G1
Filtration rate (µm)	40
Flow rate (NI/min) ^(A)	10000
Max inlet pressure (bar-MPa-psi)	10-1-145
Working pressure (bar) with manual/semi-automatic drain	0,5 ÷ 10
Working pressure (bar) with automatic drain	1,5 ÷ 10
Pressure adjustment - relieving version (bar)	0,5 ÷ 8,5
Pressure gauge adaptor	G1/8
Fluid	compressed air
Temperature (°C)	-5 ÷ 60
Condensation drain capacity (cm ³)	75
Bowl capacity (cm ³)	200
Drain capacity ^(B)	manual/semi-automatic
Weight (g)	3480
Mounting position	vertical
Recommended oil	ISO VG 32
Min. working flow rate (NI/min)	33

(A) = inlet pressure 7 bar, outlet pressure 5 bar - Δp 2 bar

(B) = manual drain with semi-automatic function at < 0,5 bar pressure

HZE3D25GS

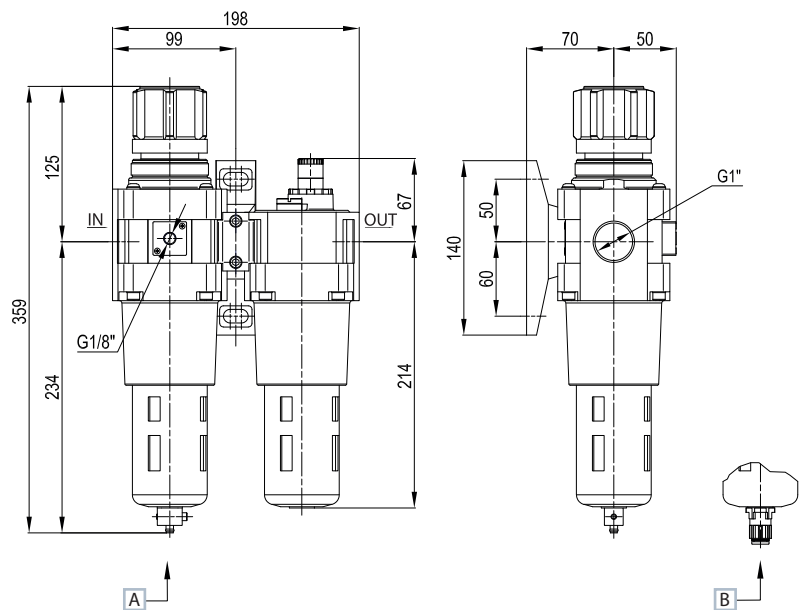

- A** Manual/semi-automatic drain ID Tube 5,5 mm
- B** Automatic drain OD Tube 8 mm

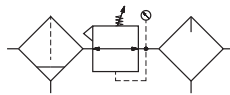

4

Filter + Regulator + Lubricator

Part no.	HZE3C25GS
Connections	G1"
Filtration rate (µm)	40
Flow rate (NI/min) ^(A)	10000
Max inlet pressure (bar-MPa-psi)	10-1-145
Pressure adjustment - relieving version (bar)	0,5 ÷ 8,5
Working pressure (bar) with manual/semi-automatic drain	0,5-10
Working pressure (bar) with automatic drain	1,5-10
Pressure gauge adaptor	G1/8
Fluid	compressed air
Temperature (°C)	-5 ÷ 60
Condensation drain capacity (cm ³)	75
Bowl capacity (cm ³)	200
Drain capacity ^(B)	manual/semi-automatic
Weight (g)	4200
Mounting position	vertical
Recommended oil	ISO VG 32
Min. working flow rate (NI/min)	33

(A) = inlet pressure 7 bar, outlet pressure 5 bar - Δp 1 bar

(B) = manual drain with semi-automatic function at < 0,5 bar pressure

HZE3C25GS

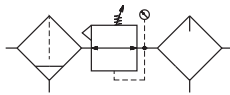
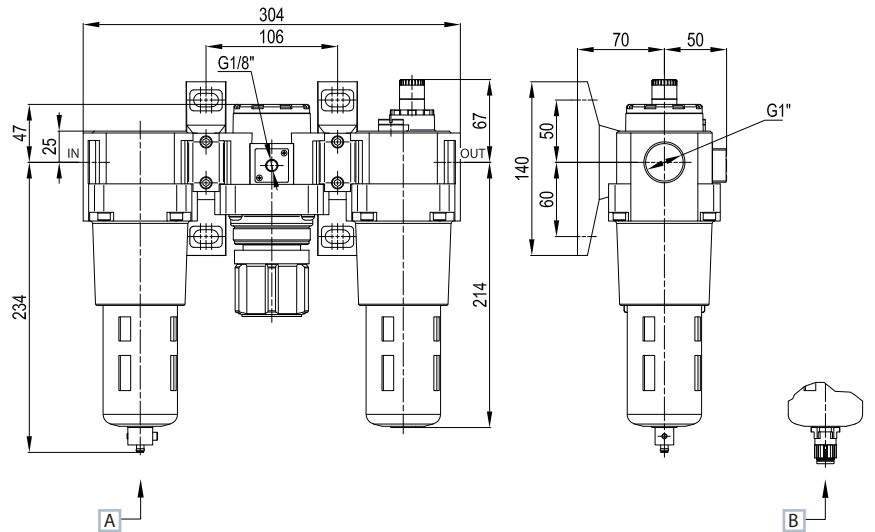

- A** Manual/semi-automatic drain ID Tube 5,5 mm
- B** Automatic drain OD Tube 8 mm

Other versions available

HZE3R25GQ/GT

HZE3B25GQ/GT



Regulator with integrated digital pressure switch size 3
HZE3R25GQ
HZE3R25GT with M8 connector

Filter regulator with integrated digital pressure switch size 3
HZE3B25GQ
HZE3B25GT with M8 connector

Accessories

Intermediate diverter block

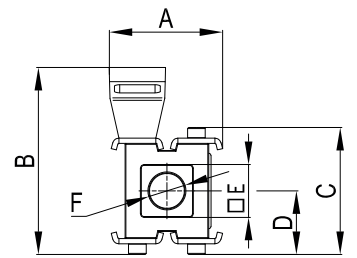
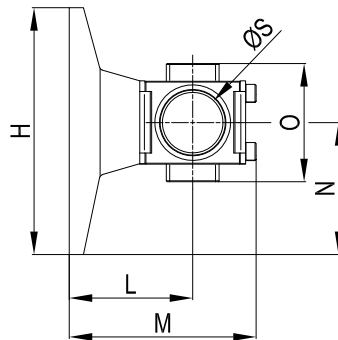
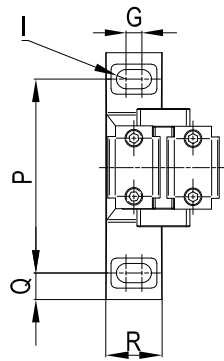

size	A	B	C	D	E	F	G	H	I	L	M	N	O	P	Q	R	ØS	Part no.
3	64	106	72	36	30	G1/2	9	140	5,5	70	106	75	67	110	15	32	34,4	HZE3N

4

Fixing elements

Assembly kit

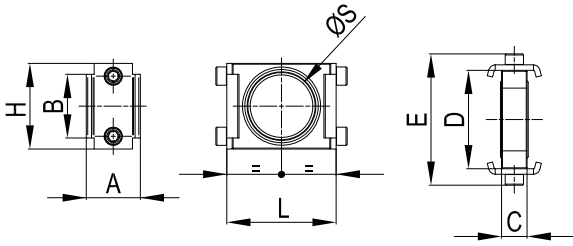

size	A	B	C	D	E	H	L	ØS	Part no.
3	30	35	14	54	72	47	60	34,4	HZE3Z200



T-bracket assembly kit

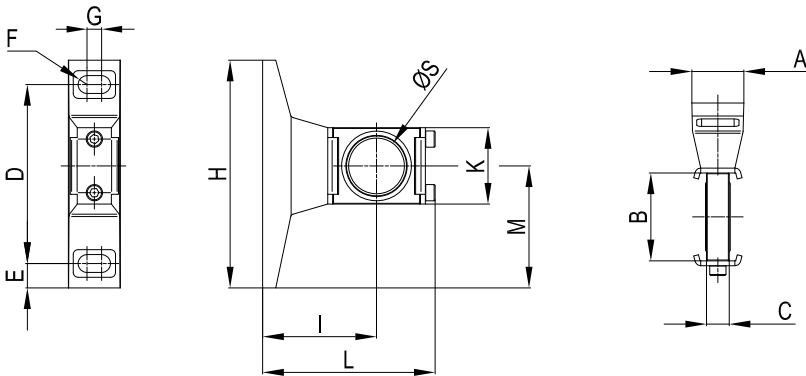

size	A	B	C	D	E	F	G	H	I	K	L	M	ØS	Part no.
3	32	54	14	110	15	5,5	9	140	70	47	106	75	34,4	HZE3Z210



L-bracket (for regulator and filter regulator)

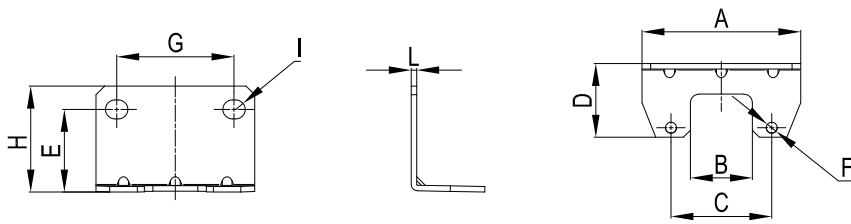

size	A	B	C	D	E	ØF	G	H	I	L	Part no.
3	92	36	58,5	43	48	6,5	68	61	5,5	3,2	HZE3Z310R

*Standard supplied with regulator and filter regulator



L-bracket (for filter and lubricator)

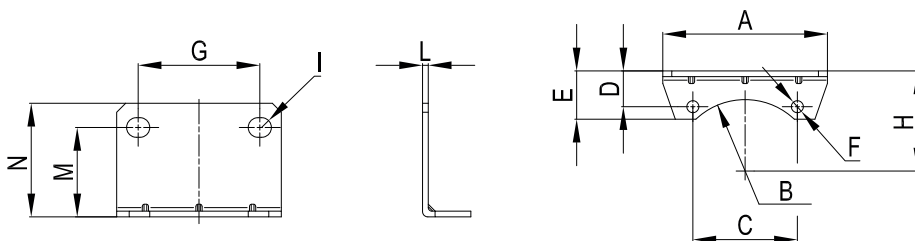

size	A	B	C	D	E	ØF	G	H	I	L	M	N	Part no.
3	92	40	58,4	20	27	6,8	68	56	5,5	3,2	50	63,5	HZE3Z310F



Spare parts for Filter regulator

HZE3Z600SS



Bowl with semi-automatic drain

HZE3Z401



Bowl with automatic drain

HZE3Z660



Filter element 40 µm

Spare parts for Regulator and filter regulator

HZE3Z602



Knob

HZE3Z658



Regulator spring
Pressure adjustment
0,5 ÷ 8,5

HZE3Z603



Ring nut for panel

HZE3Z610



Diaphragm kit with relieving

Spare parts for Lubricator

HZE3Z601



Standard bowl

HZE3Z470



Lubricator transparent dome

4

Gauges and pressure switches

HZ9P...



Pressure gauge

HZ9NPB...



Pressure gauge with flange
for panel mounting

HZ9PBS...



Pressure gauge with bracket
for panel mounting

HZ9464G



Recessed pressure gauge

HZ9N



Digital pressure switch

HZ9NP50



IP65 digital pressure switch with
connector

For technical characteristics see Chapter 5. Accessories

HZE1G/HZE2G

Coalescence purifier filters

The coalescence purifier filter is used in applications where a very high degree of filtration as well as air free from oily residues are required. The purifying filter is supplied with a coalescence filter element capable of retaining solid particles, oil vapors and condensation.

Filtration grades available:

- 0,3 µm and residual oil 0,1 mg/m³ (ISO 8573 - 1: 2010 class 2.7.2)
- 0,01 µm and residual oil 0,01 mg/m³ (ISO 8573 - 1: 2010 class 1.7.1)

ATEX version available upon request

CE Ex II 3 GD c nA II T5 -10 °C ≤ Ta ≤ 45 °C



TECHNICAL CHARACTERISTICS

Ambient temperature	2 ÷ 65 °C
Fluid	filtered compressed air 5 µm
Working pressure	10 bar
Max pressure	15 bar
Sizes	1 - 2
Filter element	0,3 µm 0,01 µm
Condensation drain	manual (standard) semi-automatic/automatic (on request)
Mounting position	vertical, a 5 µm pre-filter is to be installed upstream

CONSTRUCTIVE CHARACTERISTICS

Body	die-cast aluminium
Bowl	polycarbonate
Bowl guard	technopolymer
Filter element	high efficiency borosilicate glass microfiber filter media

CODIFICATION KEY

H	Z	E	1	G	1	0	G		B	
1	2	3	4	5	6	7				

1 Series	2 Size	3 Model	4 Thread
HZE = Air treatment with standard manual drain	1= Size 1 2= Size 2	G = Coalescence	10G = G3/8 (sz.1) 15G = G1/2 (sz.1 - 2)

5 Option	6 Version	7 ATEX option
A = Automatic drain S = Semi-automatic drain	B = Filter element 0,01 µm (red color) C = Filter element 0,3 µm (green color)	X = Atex (upon request) See ATEX Catalogue for types and versions

Coalescence purifier filters	Size			
	1		2	
Part no.	HZE1G		HZE2G	
Connections	G3/8 - G1/2		G1/2	
Filtration rate (μm)	0,3	0,01	0,3	0,01
Residual oil content (mg/m^3)	0,1	0,01	0,1	0,01
Nominal flow rate with manual drain (NI/min) ^(A)	600		1000	
Nominal flow rate with automatic drain (NI/min) ^(A)	450		750	
Condensation drain capacity (cm^3)	45		80	
Type of mounting	vertical			
Weight (Kg)	0,31		0,55	

(A) = inlet pressure 7 bar

Note: Install a 5 μm pre-filter prior to the coalescence purifier filter.

It is recommended to replace the filter element when the pressure drop (ΔP) exceeds 0,7 bar

HZE1G/HZE2G

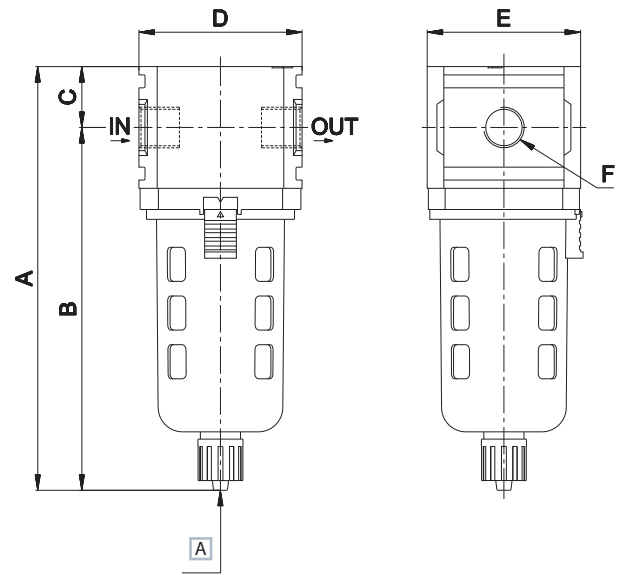

A Manual drain

Size	A	B	C	D	E	F
1	180	157	23	63	63	G3/8-G1/2
2	195	172	23	80	80	G1/2



4

Fixing elements

T-bracket assembly kit

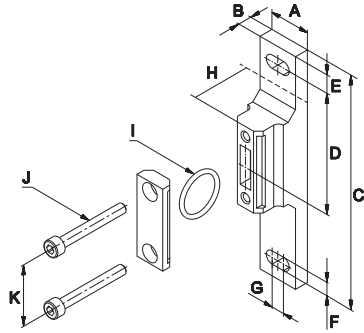

Size	A	B	C	D	E	F	G	H	ØI	J	K	Part No.
1	22	7	125	45	10	7	7	27	25,7	M5x45	32	HZE1Z210
2	22,5	7	125	45	10	7	7	37	25,7	M5x45	32	HZE2Z210

C-bracket

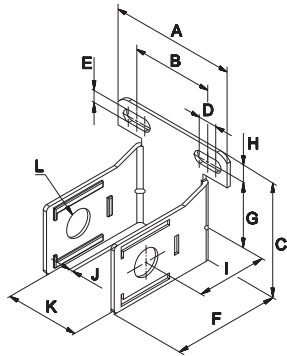

Size	A	B	C	D	E	F	G	H	I	J	K	ØL	Part No.
1	67	34,5	76	14	7	69	45	9	45	2,3	63	25	HZE1Z300
2	84	55	93,5	14	9	102	50	11	65	2,3	80	25	HZE2Z300

Spare parts

HZE1/2Z600



Standard bowl with manual drain
Size 1 HZE1Z600
Size 2 HZE2Z600

HZE1/2Z600SS



Bowl with semi-automatic drain
Size 1 HZE1Z600SS
Size 2 HZE2Z600SS

HZE7Z400



Automatic drain
Size 1-2 HZE7Z400

HZE1/2Z673L



Filter element for manual and semi-automatic drain 0,3 µm
Size 1 HZE1Z673L
Size 2 HZE2Z673L

HZE1/2Z671L



Filter element for manual and semi-automatic drain 0,01 µm
Size 1 HZE1Z671L
Size 2 HZE2Z671L

HZE1/2Z673C



Filter element for automatic drain 0,3 µm
Size 1 HZE1Z673C
Size 2 HZE2Z673C

HZE1/2Z671C



Filter element for automatic drain 0,01 µm
Size 1 HZE1Z671C
Size 2 HZE2Z671C

HZE1GD/HZE2GD

Oil separator filters with activated carbon

The activated carbon oil separator filter is used for removing oil, solvent, hydrocarbon vapors and for eliminating odors.

Residual oil content 0,003 mg/m³ (ISO 8573 - 1: 2010 class 1.7.1)

ATEX version available upon request

CE Ex II 3 GD c nA II T5 -10 °C ≤ Ta ≤ 45 °C



TECHNICAL CHARACTERISTICS

Ambient temperature	2 ÷ 30 °C
Fluid	filtered compressed and oil free air 0,01 µm
Working pressure	10 bar
Max pressure	15 bar
Sizes	1 - 2
Filter element	activated carbon
Condensation drain	manual (standard)
Mounting position	vertical, 5 µm pre-filter and 0,01 µm coalescence purifier filter are to be installed upstream

CONSTRUCTIVE CHARACTERISTICS

Body	die-cast aluminium
Bowl	polycarbonate
Bowl guard	technopolymer
Filter element	activated carbon

CODIFICATION KEY

H	Z	E	1	G	D	1	0	G	
1	2	3	4	5					

1 Series	2 Size	3 Model	4 Thread	5 ATEX option
HZE = Air treatment unit with standard manual drain	1 = Size 1 2 = Size 2	GD = Activated carbon	10G = G3/8 (sz.1) 15G = G1/2 (sz.1 - 2)	X = Atex (upon request) See ATEX Catalogue for types and versions

Coalescence purifier filters	Size	
	1	2
Connections	G3/8 - G1/2	G1/2
Residual oil content (mg/m ³)	0,003	0,003
Nominal flow rate with manual drain (NI/min) ^(A)	600	1000
Condensation drain capacity (cm ³)	45	80
Type of mounting	vertical	
Weight (Kg)	0,31	0,55

(A) = inlet pressure 7 bar

Note: install a 5 µm pre-filter and a 0,01 µm coalescence purifier filter prior to the oil separator filter with activated carbon. It is recommended to replace the filter element after every 1000 h of use.

HZE1GD/HZE2GD

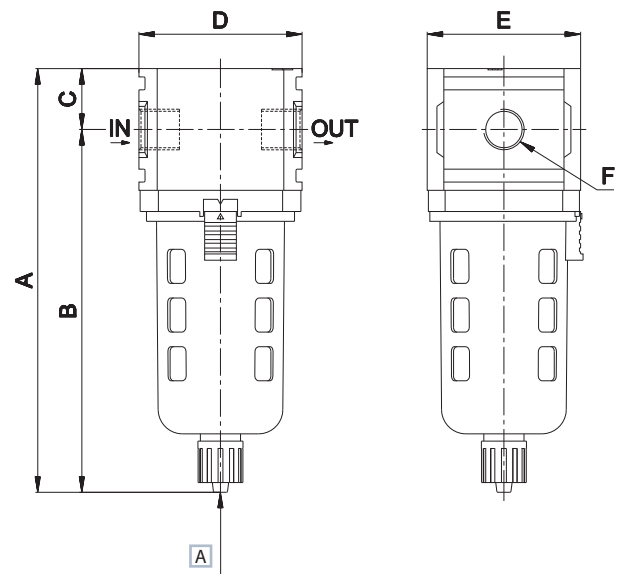

A Manual drain

size	A	B	C	D	E	F
1	180	157	23	63	63	G3/8-G1/2
2	195	172	23	80	80	G1/2



4

Fixing elements

T-bracket assembly kit

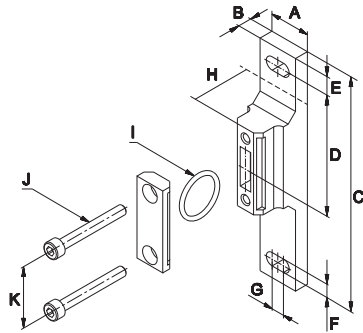

size	A	B	C	D	E	F	G	H	ØI	J	K	Part No.
1	22	7	125	45	10	7	7	27	25,7	M5x45	32	HZE1Z210
2	22,5	7	125	45	10	7	7	37	25,7	M5x45	32	HZE2Z210

Assembly kit

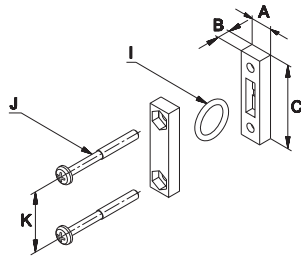

size	A	B	C	ØI	J	K	Part No.
1-2	15	7	44	25,7	M5x45	32	HZE1Z200

C-bracket

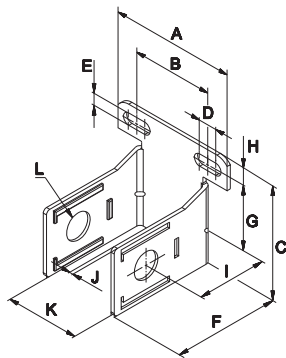

size	A	B	C	D	E	F	G	H	I	J	K	ØL	Part No.
1	67	34,5	76	14	7	69	45	9	45	2,3	63	25	HZE1Z300
2	84	55	93,5	14	9	102	50	11	65	2,3	80	25	HZE2Z300

Spare parts

HZE1/2Z600

HZE1/2Z674L



Standard bowl with manual drain
 Size 1 HZE1Z600
 Size 2 HZE2Z600

Filter element with activated carbon
 Size 1 HZE1Z674L
 Size 2 HZE2Z674L